

**ENGINEERED  
PLASTIC**

**BACKUP  
RINGS**

## Table of Contents

PTFE Back-Up Ring	CoorsTek Standard	Reference Standard	Page
Single Turn	TF91	AS8791/1	2.5
Single Turn	TF74	MS28774	2.7
Single Turn, Piston	TF1177P	AS4716 (Groove)	2.9
Single Turn, Rod	TF1177R	AS4716 (Groove)	2.11
Single Turn, Piston	TF1201P	AS5860	2.13
Single Turn, Rod	TF1201R	AS5860	2.16
Single Turn, Heavy Duty	TF450	BACR12BM	2.19
Single Turn, Extended Series	TF74C	COORSTEK	2.22
Solid, Extended Series	TF74S	COORSTEK	2.22
Solid	TF95	MS27595	2.26
Solid, Heavy Duty	TF456	BACR12BP	2.28
Spiral	TF82	MS28782	2.30
Spiral	TF83	MS28783	2.32
Single Turn, Boss Connection	TF58	MS9058	2.33
Single Turn, Tube Fitting	TF73	MS28773	2.33
Spiral, Extended Series	TF171	COORSTEK	2.34

## Part Numbering System

EXAMPLE: **TF456 - 119 - 801**

**TFXXX - XXX - XXX**

**BASIC PART NUMBER**

**DASH NO.**

**MATERIAL CODE**

(unfilled PTFE if omitted)

### Alternate Numbering System:

**MS28**

**AS0791/1-119**

## A Word About Back-Up Rings

### Function of PTFE Back-Up Rings

PTFE back-up rings are designed to prevent extrusion in rubber O-ring sealing systems.

Rubber O-rings generally serve as effective seals for dynamic and static applications in hydraulic and pneumatic systems equipment. One big drawback of rubber O-rings is their tendency to extrude into the clearance of mating surfaces when subjected to increasing pressures and temperatures. Elevated temperatures (160 °F and higher) impose a severe burden on the physical and mechanical properties of rubber O-rings, which further increases their tendency to extrude.

The combination of high pressures and high temperatures is a common occurrence in present day fluid systems. Moreover, the trend is toward still higher pressures and longer resident times at elevated temperatures. This places more emphasis on the role of the back-up ring in preventing O-Ring extrusion.

### Standard Configurations

There are three basic types of PTFE back-up rings in use: single turn (scarf cut), multi-turn (spiral cut), and solid (uncut) configurations.

A new series of Single Turn Cut Back-Up Rings, designated as AS8791/1, has been added to this catalog. The AS8791/1 configuration was developed to provide improved fit in the O-Ring Glands designed to MIL-P-5514 Rev. C, D, E and MIL-G-5514. The M8791/1 Series Back-Up Rings have superseded MS28774 Back-Up Rings for new design.

### Heavy Duty Back-Up Rings

Heavy Duty back-up rings are configured with a greater axial thickness (T) dimension. The extra thickness provides more extrusion protection for O-Rings. These rings are interchangeable with MS27595, MS28774, MS28782 and MS28783 back-up rings used in MIL-G-5514 packing glands. Heavy duty rings are available in the solid (uncut) TF456 and in the single turn (scarf cut) TF450 configurations.

Tables of these standards and a cross reference to applicable CoorsTek catalog numbers are given in this catalog.

### Extended Sizes

In addition to the military standards, CoorsTek supplies three series of extended dash size standards, which provide back-up rings for all O-Rings in the Aerospace Standard AS568A Uniform Numbering System. These configurations, TF74S, TF74C, and TF171 have proven very useful to fluid systems designers because of the added flexibility in size selection. Because extended sizes usually are available directly from the factory or distributor stocks, industrial users are assured of the same quality and service that applies to the most sophisticated aerospace applications.

### Filled Back-Up Rings

For applications where sealing systems are subjected to severe duty cycles, or where pressures exceed 3,000 psi and temperatures are above 275 °F, filled PTFE back-up rings are very useful.

1 tetralon materials

2 back-up rings

3 metaplast II spring seals

4 tetracap & unilock seals

5 tetraflex piston seals

6 o-rings

7 metallic seals

8 tetralon bearings

# Back-Up Rings

## General Information

TF91 is a material well suited for high-pressure, high-temperature applications against hardened and/or use with chrome non-abrasive compounds. It is suitable for use against both hard anodized surfaces and most non-heat hardenable metals. Both of these materials provide wear resistance superior to unfilled PTFE when used in conjunction with MIL-P-83461 O-Ring compound in MIL-H-83282 and MIL-H-5606 hydraulic fluids.

In addition to the more common fills such as glass fibers, CoorsTek has accumulated considerable experience with back-up rings of Nylon, Kel-F, FEP, UHMW, PEEK, and others. We have produced this catalog using these materials as well as more specialized compounds of PTFE.

CoorsTek is a leading designer and manufacturer of components, integrated assemblies for the semiconductor capital equipment market, and other high technology applications. Serving a wide variety of industries in the global economy, CoorsTek uses technical ceramics, precision-machined metals, engineered plastics, and other high-performance materials to provide Amazing Solutions to enable our customers' products to overcome technological barriers and improve performance – especially in demanding or severe service environments.

The CoorsTek highly qualified staff may assist with material selection and product design. Please contact us today at 310-322-8030 for more information.

Care should be taken in selecting a compound that is compatible with the gland or rod materials of construction to prevent abrasion or wear problems.

Please contact your CoorsTek distributor or the factory direct for assistance in the selection of materials that will best fit your needs.

# Back-Up Rings

## TF91 Single Turn

**TF91**  
(AS8791/1)

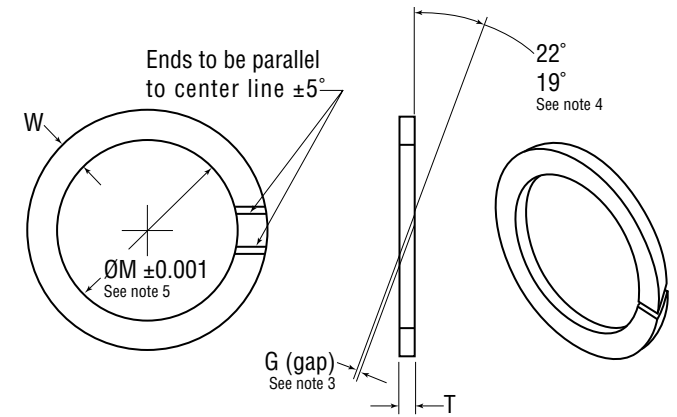

- Notes:**
- All dimensions are in inches
  - Surfaces shall be smooth and free from irregularities. Edges shall be clear and sharp.
  - Scarf cut: Placing Back-Up Ring over mandrel of  $\text{Ø } M \pm 0.001$  scarf cut gap shall not exceed dimension G and no overlap of the scarf ends is permitted beyond dimension T.
  - Direction of scarf cut is optional. Exceptions to scarf cut angle:
- | Dash No. | -004      | -005      | -006      | -007      |
|----------|-----------|-----------|-----------|-----------|
| Angle    | 42° - 45° | 33° - 36° | 30° - 33° | 24° - 27° |
5. For use in standard grooves conforming to MIL-G-5514 and MIL-P-5514C, D and E revisions.

DASH NO.	ØM	T	W	G
-004	0.076			
-005	0.108			
-006	0.123			
-007	0.154			
-008	0.185			
-009	0.217			
-010	0.248			
-011	0.310			
-012	0.373			
-013	0.438	0.052	0.054	0.005
-014	0.501	0.048	0.052	0.000
-015	0.563			
-016	0.626			
-017	0.688			
-018	0.751			
-019	0.813			
-020	0.881			
-021	0.943			
-022	1.006			
-023	1.068			

DASH NO.	ØM	T	W	G
-024	1.131			
-025	1.193			
-026	1.256	0.052	0.054	0.005
-027	1.318	0.048	0.052	0.000
-028	1.381			
-110	0.373			
-111	0.435			
-112	0.498			
-113	0.560			
-114	0.623			
-115	0.685			
-116	0.748			
-117	0.815	0.056	0.087	0.006
-118	0.878	0.052	0.085	0.000
-119	0.940			
-120	1.003			
-121	1.065			
-122	1.128			
-123	1.190			
-124	1.253			

DASH NO.	ØM	T	W	G
-125	1.315			
-126	1.380			
-127	1.442			
-128	1.505			
-129	1.564			
-130	1.627			
-131	1.689			
-132	1.752	0.056	0.087	0.006
-133	1.814	0.052	0.085	0.000
-134	1.877			
-135	1.940			
-136	2.002			
137	2.065			
-138	2.127			
-139*	2.190			
-210	0.748			
-211	0.810			
-212	0.873	0.064	0.120	0.006
-213	0.935	0.060	0.118	0.000
-214	0.998			

- 1 tetralon materials
- 2 back-up rings
- 3 metaplast II spring seals
- 4 tetracap & unilock seals
- 5 tetraflex piston seals
- 6 o-rings
- 7 metallic seals
- 8 tetralon bearings

# Back-Up Rings

TF91 Single Turn

DASH NO.	ØM	T	W	G	DASH NO.	ØM	T	W	G	DASH NO.	ØM	T	W	G
-215	1.060				-327	1.748				-345	3.997			
-216	1.123				-328	1.873				-346	4.122			
-217	1.185				-329	1.998				-347	4.247	0.090	0.184	0.007
-218	1.248			0.006	-330	2.123				-348	4.372	0.086	0.182	0.000
-219	1.310			0.000	-331	2.248				-349	4.497			
-220	1.373				-332	2.373				-425	4.497			
-221	1.435				-333	2.498				-426	4.622			
-222	1.498	0.064	0.120		-334	2.623				-427	4.747			
-223	1.625	0.060	0.118		-335	2.748	0.090	0.184	0.007	-428	4.872			
-224	1.750				-336	2.873	0.086	0.182	0.000	-429	4.997			
-225	1.875				-337	2.997				-430	5.122			
-226	2.000			0.007	-338	3.122				-431	5.247	0.122	0.237	0.008
-227	2.125			0.000	-339	3.247				-432	5.372	0.118	0.235	0.000
-228	2.250				-340	3.372				-433	5.497			
-229	2.375				-341	3.497				-434	5.622			
-230	2.500				-342	3.747				-435	5.747			
-325	1.498	0.090	0.184	0.007	-343	3.872				-436	5.872			
-326	1.623	0.086	0.182	0.000	-344	3.872				-437*	5.997			

\*For larger Back-Up Rings in this series, uncut Back-Up Rings TF95 are recommended

# Back-Up Rings

TF74 Single Turn

**TF74**  
(MS28774)

**Notes:**  
 1. All dimensions are in inches  
 2. Surfaces shall be smooth and free from irregularities. Edges shall be clear and sharp.  
 3. Scarf cut: Placing Back-Up Ring over mandrel of Ø M ±0.001 scarf cut gap shall not exceed dimension G and no overlap of the scarf ends is permitted beyond dimension T.  
 4. Direction of scarf cut is optional. Exceptions to scarf cut angle:  

Dash No.	-004	-005	-006	-007
Angle	35° - 39°	30° - 33°	27° - 30°	23° - 26°

 5. For use in standard grooves conforming to MIL-G-5514 and MIL-P-5514C, D and E revisions.

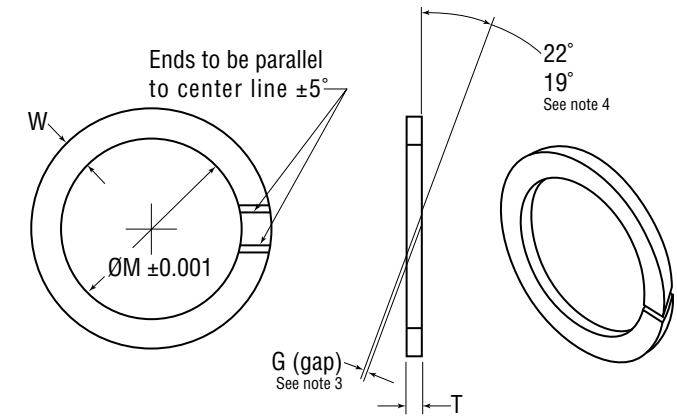

DASH NO.	ØM	T	W	G	DASH NO.	ØM	T	W	G	DASH NO.	ØM	T	W	G
-004	0.109				-025	1.210				-127	1.459			
-005	0.124				-026	1.273	0.052	0.054	0.005	-128	1.522			
-006	0.140				-027	1.335	0.045	0.052	0.000	-129	1.584			
-007	0.171				-028	1.398				-130	1.647			
-008	0.202				-110	0.390				-131	1.709			
-009	0.234				-111	0.452				-132	1.772			
-010	0.265				-112	0.515				-133	1.834			
-011	0.327				-113	0.577				-134	1.897			
-012	0.390				-114	0.640				-135	1.959			
-013	0.455				-115	0.702				-136	2.022			
-014	0.518	0.052	0.054	0.005	-116	0.765				-137	2.084	0.052	0.087	0.006
-015	0.580	0.045	0.052	0.000	-117	0.832				-138	2.147	0.045	0.085	0.000
-016	0.643				-118	0.895	0.052	0.087	0.006	-139	2.209			
-017	0.705				-119	0.957	0.045	0.085	0.000	-140	2.258			
-018	0.768				-120	1.020				-141*	2.320			
-019	0.830				-121	1.082				-142*	2.383			
-020	0.898				-122	1.145				-143*	2.445			
-021	0.960				-123	1.207				-144	2.508			
-022	1.023				-124	1.270				-145	2.570			
-023	1.085				-125	1.332				-146	2.633			
-024	1.148				-126	1.397				-147	2.685			

- 1 tetralon materials
- 2 back-up rings
- 3 metaplast II spring seals
- 4 tetracap & unilock seals
- 5 tetratflex piston seals
- 6 o-rings
- 7 metallic seals
- 8 tetralon bearings

# Back-Up Rings

TF74 Single Turn

DASH NO.	ØM	T	W	G	DASH NO.	ØM	T	W	G	DASH NO.	ØM	T	W	G
-148	2.758	0.052	0.087	0.006	-242	4.006				-428	4.926			
-149	2.820	0.045	0.085	0.000	-243	4.131				-429	5.051			
-210	0.766				-244	4.256	0.052	0.120	0.007	-430	5.176			
-211	0.828				-245	4.381	0.045	0.118	0.000	-431	5.301			
-212	0.891				-246	4.506				-432	5.426			
-213	0.953				-247	4.631				-433	5.551			
-214	1.016				-325	1.513				-434	5.676			
-215	1.078				-326	1.638				-435	5.801			
-216	1.141			0.006	-327	1.763				-436	5.926			
-217	1.203			0.000	-328	1.888				-437	6.051			
-218	1.266				-329	2.013				-438	6.274			0.008
-219	1.334				-330	2.138				-439	6.524			0.000
-220	1.397				-331	2.268				-440	6.774			
-221	1.459				-332	2.393				-441	7.024			
-222	1.522				-333	2.518				-442	7.274			
-223	1.647				-334	2.643				-443	7.524			
-224	1.772				-335	2.768				-444	7.774	0.110	0.237	
-225	1.897	0.052	0.120		-336	2.893				-445	8.024	0.100	0.235	
-226	2.022	0.045	0.118		-337	3.018	0.075	0.184	0.007	-446	8.524			
-227	2.147				-338	3.143	0.065	0.182	0.000	-447	9.024			
-228	2.272				-339	3.273				-448	9.524			
-229	2.397				-340	3.398				-449	10.024			
-230	2.522				-341	3.523				-450	10.524			
-231	2.631				-342	3.648				-451	11.024			
-232	2.756			0.007	-343	3.773				-452	11.524			
-233	2.881			0.000	-344	3.898				-453	12.024			
-234	3.006				-345	4.028				-454	12.524			
-235	3.131				-346	4.153				-455	13.024			0.010
-236	3.256				-347	4.278				-456	13.524			0.000
-237	3.381				-348	4.403				-457	14.024			
-238	3.506				-349	4.528				-458	14.524			
-239	3.631				-425	4.551				-459	15.024			
-240	3.756				-426	4.676	0.110	0.237	0.008	-460	15.524			
-241	3.881				-427	4.801	0.100	0.235	0.000					

# Back-Up Rings

TF1177P, Single Turn, Piston

**TF1177P**  
(AS4716)

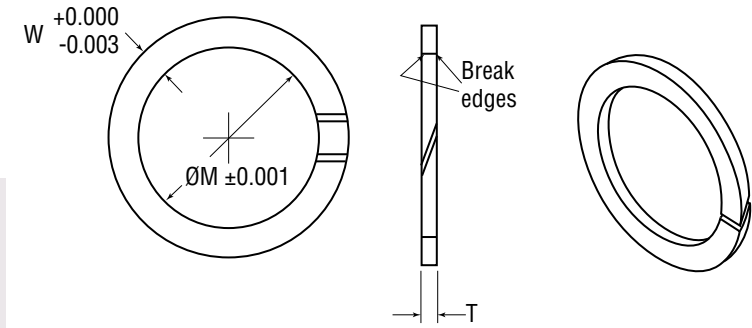

**Notes:**  
 1. All dimensions are in inches  
 2. Surfaces shall be smooth and free from irregularities. Edges shall be clear and sharp.  
 3. Diameters are average and do not imply roundness.  
 4. For use with standard grooves conforming to AS4716.  
 5. Made of thermoplastic material. Refer to Materials section.

DASH NO.	ØM	O.D. REF.	W	T	DASH NO.	ØM	O.D. REF.	W	T	DASH NO.	ØM	O.D. REF.	W	T
-004	0.079	0.191			-106	0.189	0.361			-133	1.821	1.993		
-005	0.110	0.222	0.056		-107	0.220	0.392			-134	1.884	2.056		
-006	0.124	0.236			-108	0.251	0.423			-135	1.947	2.119		
-007	0.155	0.267			-109	0.314	0.486			-136	2.009	2.181		
-008	0.188	0.298			-110	0.379	0.551			-137	2.072	2.244		
-009	0.220	0.330			-111	0.442	0.614			-138	2.134	2.306		
-010	0.251	0.361			-112	0.504	0.676			-139	2.197	2.369		
-011	0.313	0.423			-113	0.567	0.739			-140	2.259	2.431		
-012	0.376	0.486			-114	0.629	0.801			-141	2.322	2.494	0.086	0.055
-013	0.441	0.551			-115	0.692	0.864			-142	2.384	2.556		
-014	0.504	0.614			-116	0.754	0.926			-143	2.447	2.619		
-015	0.566	0.676			-117	0.820	0.992			-144	2.509	2.681		
-016	0.629	0.739		0.055	-118	0.882	1.054			-145	2.572	2.744		
-017	0.691	0.801		0.045	-119	0.945	1.117	0.086	0.055	-146	2.634	2.806		
-018	0.754	0.864	0.055		-120	1.007	1.179			-147	2.697	2.869		
-019	0.816	0.926			-121	1.070	1.242			-148	2.759	2.931		
-020	0.882	0.992			-122	1.132	1.304			-149	2.822	2.994		
-021	0.944	1.054			-123	1.195	1.367			-210	0.752	0.992		
-022	1.007	1.117			-124	1.257	1.429			-211	0.814	1.054		
-023	1.069	1.179			-125	1.320	1.492			-212	0.877	1.117		
-024	1.132	1.242			-126	1.382	1.554			-213	0.939	1.179		
-025	1.194	1.304			-127	1.445	1.617			-214	1.002	1.242		
-026	1.257	1.367			-128	1.507	1.679			-215	1.064	1.304	0.120	0.055
-027	1.319	1.429			-129	1.570	1.742			-216	1.127	1.367		0.045
-028	1.382	1.492			-130	1.634	1.806			-217	1.189	1.429		
-104	0.126	0.298	0.086	0.055	-131	1.696	1.868			-218	1.252	1.492		
-105	0.158	0.330		0.045	-132	1.759	1.931			-219	1.314	1.554		



# Back-Up Rings

TF1177P Single Turn, Piston

DASH NO.	ØM	O.D. REF.	W	T	DASH NO.	ØM	O.D. REF.	W	T	DASH NO.	ØM	O.D. REF.	W	T
-220	1.377	1.617			-327	1.749	2.119			-432	5.375	5.851		
-221	1.439	1.679			-328	1.874	2.244			-433	5.500	5.976		
-222	1.502	1.742			-329	1.999	2.369			-434	5.625	6.101		
-223	1.628	1.868			-330	2.124	2.494			-435	5.750	6.226		
-224	1.753	1.993			-331	2.249	2.619			-436	5.875	6.351		
-225	1.879	2.119			-332	2.374	2.744			-437	6.000	6.476		
-226	2.004	2.244			-333	2.499	2.869			-438	6.250	6.726		
-227	2.129	2.369			-334	2.624	2.994			-439	6.500	6.976		
-228	2.254	2.494			-335	2.749	3.119			-440	6.750	7.226		
-229	2.379	2.619			-336	2.874	3.244			-441	7.000	7.476		
-230	2.504	2.744			-337	2.999	3.369			-442	7.250	7.726		
-231	2.629	2.869			-338	3.124	3.494	0.185	0.075	-443	7.500	7.976		
-232	2.754	2.994			-339	3.249	3.619		0.065	-444	7.750	8.226		
-233	2.879	3.119	0.120	0.055	-340	3.374	3.744			-445	8.000	8.476		
-234	3.004	3.244		0.045	-341	3.499	3.869			-446	8.500	8.976	0.238	0.110
-235	3.129	3.369			-342	3.624	3.994			-447	9.000	9.476		0.100
-236	3.254	3.494			-343	3.749	4.119			-448	9.500	9.976		
-237	3.379	3.619			-344	3.874	4.244			-449	10.000	10.476		
-238	3.504	3.744			-345	3.999	4.369			-450	10.500	10.976		
-239	3.629	3.869			-346	4.124	4.494			-451	11.000	11.476		
-240	3.754	3.994			-347	4.249	4.619			-452	11.500	11.976		
-241	3.879	4.119			-348	4.374	4.744			-453	12.000	12.476		
-242	4.004	4.244			-349	4.499	4.869			-454	12.500	12.976		
-243	4.129	4.369			-425	4.500	4.976			-455	13.000	13.476		
-244	4.254	4.494			-426	4.625	5.101			-456	13.500	13.976		
-245	4.379	4.619			-427	4.750	5.226			-457	14.000	14.476		
-246	4.504	4.744			-428	4.875	5.351	0.238	0.110	-458	14.500	14.976		
-247	4.629	4.869			-429	5.000	5.476		0.100	-459	15.000	15.476		
-325	1.498	1.868	0.185	0.075	-430	5.125	5.601			-460	15.500	15.976		
-326	1.623	1.993		0.065	-431	5.250	5.726							

# Back-Up Rings

TF1177R, Single Turn, Rod

**Notes:**

- All dimensions are in inches
- Surfaces shall be smooth and free from irregularities. Edges shall be clear and sharp.
- Diameters are average and do not imply roundness.
- For use with standard grooves conforming to AS4716.
- Made of thermoplastic material. Refer to Materials section.

**TF1177R (AS4716)**

DASH NO.	ØM	O.D. REF.	W	T	DASH NO.	ØM	O.D. REF.	W	T	DASH NO.	ØM	O.D. REF.	W	T
-004	0.076	0.188			-106	0.185	0.357			-133	1.809	1.981		
-005	0.108	0.220	0.056		-107	0.217	0.389			-134	1.872	2.044		
-006	0.123	0.235			-108	0.248	0.420			-135	1.935	2.107		
-007	0.154	0.266			-109	0.310	0.482			-136	1.997	2.169		
-008	0.185	0.295			-110	0.372	0.544			-137	2.060	2.232		
-009	0.217	0.327			-111	0.434	0.606			-138	2.122	2.294		
-010	0.248	0.358			-112	0.497	0.669			-139	2.185	2.357		
-011	0.310	0.420			-113	0.559	0.731			-140	2.247	2.419		
-012	0.373	0.483			-114	0.622	0.794			-141	2.310	2.482	0.086	0.055
-013	0.434	0.544			-115	0.684	0.856			-142	2.372	2.544		
-014	0.497	0.607			-116	0.747	0.919			-143	2.435	2.607		
-015	0.559	0.669			-117	0.809	0.981			-144	2.497	2.669		
-016	0.622	0.732		0.055	-118	0.872	1.044			-145	2.560	2.732		
-017	0.684	0.794		0.045	-119	0.934	1.106	0.086	0.055	-146	2.622	2.794		
-018	0.747	0.857	0.055		-120	0.997	1.169		0.045	-147	2.685	2.857		
-019	0.809	0.919			-121	1.059	1.231			-148	2.747	2.919		
-020	0.872	0.982			-122	1.122	1.294			-149	2.810	2.982		
-021	0.934	1.044			-123	1.184	1.356			-210	0.747	0.987		
-022	0.997	1.107			-124	1.247	1.419			-211	0.809	1.049		
-023	1.059	1.169			-125	1.309	1.481			-212	0.872	1.112		
-024	1.122	1.232			-126	1.372	1.544			-213	0.934	1.174		
-025	1.184	1.294			-127	1.434	1.606			-214	0.997	1.237		
-026	1.247	1.357			-128	1.497	1.669			-215	1.059	1.299	0.120	0.055
-027	1.309	1.419			-129	1.559	1.731			-216	1.122	1.362		0.045
-028	1.372	1.482			-130	1.622	1.794			-217	1.184	1.424		
-104	0.123	0.295	0.086	0.055	-131	1.684	1.856			-218	1.247	1.487		
-105	0.154	0.326		0.045	-132	1.747	1.919			-219	1.309	1.549		

1 tetralon materials  
 2 back-up rings  
 3 metaplast II spring seals  
 4 tetracap & unilock seals  
 5 tetraflex piston seals  
 6 o-rings  
 7 metallic seals  
 8 tetralon bearings

# Back-Up Rings

TF1177R Single Turn, Rod

DASH NO.	ØM	O.D. REF.	W	T	DASH NO.	ØM	O.D. REF.	W	T	DASH NO.	ØM	O.D. REF.	W	T
-220	1.372	1.612			-327	1.747	2.115			-432	5.371	5.843		
-221	1.434	1.674			-328	1.872	2.240			-433	5.496	5.968		
-222	1.497	1.737			-329	1.997	2.365			-434	5.621	6.093		
-223	1.622	1.862			-330	2.122	2.490			-435	5.746	6.218		
-224	1.747	1.987			-331	2.247	2.615			-436	5.871	6.343		
-225	1.872	2.112			-332	2.372	2.740			-437	5.996	6.468		
-226	1.997	2.237			-333	2.497	2.865			-438	6.246	6.718		
-227	2.122	2.362			-334	2.622	2.990			-439	6.496	6.968		
-228	2.247	2.487			-335	2.747	3.115			-440	6.746	7.218		
-229	2.372	2.612			-336	2.872	3.240			-441	6.996	7.468		
-230	2.497	2.737			-337	2.996	3.364			-442	7.246	7.718		
-231	2.622	2.862			-338	3.121	3.489	0.184	0.075 0.065	-443	7.496	7.968		
-232	2.747	2.987			-339	3.246	3.614			-444	7.746	8.218		
-233	2.872	3.112	0.120	0.055 0.045	-340	3.371	3.739			-445	7.996	8.468		
-234	2.996	3.236			-341	3.496	3.864			-446	8.496	8.968	0.236	0.110 0.100
-235	3.121	3.361			-342	3.621	3.989			-447	8.996	9.468		
-236	3.246	3.486			-343	3.746	4.114			-448	9.496	9.968		
-237	3.371	3.611			-344	3.871	4.239			-449	9.996	10.468		
-238	3.496	3.736			-345	3.996	4.364			-450	10.496	10.968		
-239	3.621	3.861			-346	4.121	4.489			-451	10.996	11.468		
-240	3.746	3.986			-347	4.246	4.614			-452	11.496	11.968		
-241	3.871	4.111			-348	4.371	4.739			-453	11.996	12.468		
-242	3.996	4.236			-349	4.496	4.864			-454	12.496	12.968		
-243	4.121	4.361			-425	4.496	4.968			-455	12.996	13.468		
-244	4.246	4.486			-426	4.621	5.093			-456	13.496	13.968		
-245	4.371	4.611			-427	4.746	5.218			-457	13.996	14.468		
-246	4.496	4.736			-428	4.871	5.343	0.236	0.110 0.100	-458	14.496	14.968		
-247	4.621	4.861			-429	4.996	5.468			-459	14.996	15.468		
-325	1.497	1.865	0.184	0.075 0.065	-430	5.121	5.593			-460	15.496	15.968		
-326	1.622	1.990			-431	5.246	5.718							

# Back-Up Rings

TF1201P Single Turn, Piston

**TF1201P**  
(AS5860)

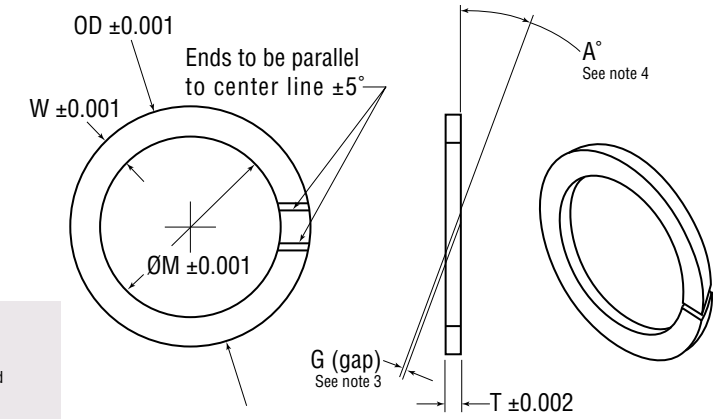

**Notes:**  
 1. All dimensions are in inches  
 2. Surfaces shall be smooth and free from irregularities. Edges shall be clear and sharp.  
 3. Scarf cut: Placing Back-Up Ring over mandrel of Ø M ±0.001 scarf cut gap shall not exceed dimension G and no overlap of the scarf ends is permitted beyond dimension T.  
 4. Direction of scarf cut is optional.  
 5. For use in standard grooves conforming to AS5857

DASH NO.	ØM	OD	T	W	G	A Degrees	DASH NO.	ØM	OD	T	W	G	A Degrees
-004	0.079	—				35°-39°	-026	1.262	—				
-005	0.111	—				32°-36°	-027	1.325	—	0.054	0.052	0.005 0.000	19°-22°
-006	0.124	—				29°-33°	-028	1.388	—				
-007	0.155	—				24°-27°	-104	0.122	—				31°-35°
-008	0.187	—					-105	0.153	—				26°-29°
-009	0.220	—					-106	0.185	—				23°-26°
-010	0.251	—					-107	0.218	—				
-011	0.314	—					-108	0.250	—				
-012	0.379	—					-109	0.313	—				
-013	0.444	—					-110	0.378	—				
-014	0.507	—					-111	0.441	—				
-015	0.569	—	0.054	0.052	0.005 0.000		-112	0.505	—				
-016	0.632	—				19°-22°	-113	0.571	—	0.058	0.081	0.006 0.000	
-017	0.694	—					-114	0.637	—				
-018	0.757	—					-115	0.700	—				19°-22°
-019	0.819	—					-116	0.762	—				
-020	0.885	—					-117	0.828	—				
-021	0.947	—					-118	0.890	—				
-022	1.010	—					-119	0.953	—				
-023	1.072	—					-120	1.015	—				
-024	1.135	—					-121	1.078	—				
-025	1.198	—					-122	1.140	—				

- 1 tetralon materials
- 2 back-up rings
- 3 metaplast II spring seals
- 4 tetracap & unlock seals
- 5 tetraflex piston seals
- 6 o-rings
- 7 metallic seals
- 8 tetralon bearings

# Back-Up Rings

TF1201P Single Turn, Piston

DASH NO.	ØM	OD	T	W	G	A Degrees
-123	1.203	—				
-124	1.265	—				
-125	1.329	—				19°-22°
-126	1.392	—				
-127	1.455	—				
-128	—	1.678				
-129	—	1.741				
-130	—	1.805				
-131	—	1.867	0.058	0.081		
-132	—	1.930				
-133	—	1.992				12°-15°
-134	—	2.055				
-135	—	2.118				
-136	—	2.180				
-137	—	2.243				
-138	—	2.305				
-139	—	2.368				
-210	0.768	—			0.006	
-211	0.830	—			0.000	
-212	0.893	—				
-213	0.955	—				
-214	1.018	—				
-215	1.080	—				
-216	1.143	—				19°-22°
-217	1.205	—				
-218	1.268	—	0.062	0.111		
-219	1.331	—				
-220	1.395	—				
-221	1.457	—				
-222	—	1.743				
-223	—	1.867				
-224	—	1.992				
-225	—	2.118				12°-15°
-226	—	2.243				
-227	—	2.368				
-228	—	2.493				
-229	—	2.618	0.062	0.111	0.006	12°-15°
-230	—	2.745			0.000	
-325	—	1.867				
-326	—	1.992				
-327	—	2.118				
-328	—	2.243				
-329	—	2.368				19°-22°
-330	—	2.494				
-331	—	2.620				
-332	—	2.747				
-333	—	2.873				
-334	—	2.993				
-335	—	3.118				
-336	—	3.243				
-337	—	3.368	0.088	0.171	0.007	
-338	—	3.493			0.000	
-339	—	3.618				
-340	—	3.743				
-341	—	3.868				
-342	—	3.994				
-343	—	4.120				
-344	—	4.247				
-345	—	4.373				12°-15°
-346	—	4.500				
-347	—	4.626				
-348	—	4.753				
-349	—	4.879				
-425	—	4.974				
-426	—	5.099				
-427	—	5.224				
-428	—	5.349	0.128	0.226	0.008	
-429	—	5.474			0.000	
-430	—	5.599				
-431	—	5.724				

# Back-Up Rings

TF1201P Single Turn, Piston

DASH NO.	ØM	OD	T	W	G	A Degrees
-432	—	5.849				
-433	—	5.975	0.128	0.226	0.008	12°-15°
-434	—	6.102			0.000	
-435	—	6.228				
-436	—	6.355	0.128	0.226	0.008	12°-15°
-437	—	6.481			0.000	

1 tetralon materials  
2 back-up rings  
3 metaplast II spring seals  
4 tetracap & unilock seals  
5 tetraflex piston seals  
6 o-rings  
7 metallic seals  
8 tetralon bearings



# Back-Up Rings

TF1201R Single Turn, Rod

## TF1201R (AS5860)

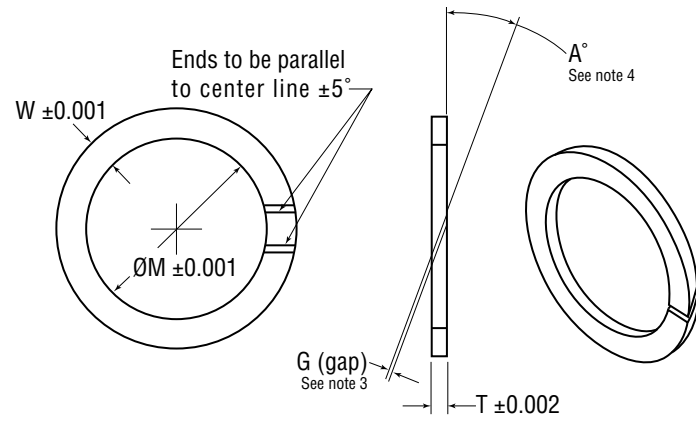

**Notes:**  
 1. All dimensions are in inches  
 2. Surfaces shall be smooth and free from irregularities. Edges shall be clear and sharp.  
 3. Scarf cut: Placing Back-Up Ring over mandrel of Ø M ±0.001 scarf cut gap shall not exceed dimension G and no overlap of the scarf ends is permitted beyond dimension T.  
 4. Direction of scarf cut is optional.  
 5. For use in standard grooves conforming to AS5857

DASH NO.	ØM	T	W	G	A
-004	0.076				35°-39°
-005	0.108				32°-36°
-006	0.123				29°-33°
-007	0.154				24°-27°
-008	0.185				
-009	0.217				
-010	0.248				
-011	0.310				
-012	0.373				
-013	0.435				
-014	0.498	0.054	0.053	0.005	
-015	0.560			0.000	
-016	0.623				19°-22°
-017	0.685				
-018	0.748				
-019	0.810				
-020	0.873				
-021	0.935				
-022	0.998				
-023	1.060				
-024	1.123				
-025	1.185				

DASH NO.	ØM	T	W	G	A
-026	1.248				
-027	1.311	0.054	0.053	0.005	19°-22°
-028	1.374			0.000	
-104	0.123				31°-35°
-105	0.154				26°-29°
-106	0.185				23°-26°
-107	0.217				
-108	0.248				
-109	0.310				
-110	0.373				
-111	0.435				
-112	0.498				
-113	0.560	0.058	0.081	0.006	
-114	0.623			0.000	
-115	0.685				19°-22°
-116	0.748				
-117	0.810				
-118	0.873				
-119	0.935				
-120	0.998				
-121	1.060				
-122	1.123				

# Back-Up Rings

TF1201R Single Turn, Rod

DASH NO.	ØM	T	W	G	A
-123	1.185				
-124	1.248				
-125	1.311				
-126	1.374				
-127	1.437				
-128	1.501				
-129	1.563				
-130	1.627				19°-22°
-131	1.689	0.058	0.081		
-132	1.753				
-133	1.816				
-134	1.879				
-135	1.943				
-136	2.005				
-137	2.069				
-138	2.123				
-139	2.185				12°-15°
-210	0.748			0.006	
-211	0.810			0.000	
-212	0.873				
-213	0.935				
-214	0.998				
-215	1.060				
-216	1.123				19°-22°
-217	1.185				
-218	1.248	0.062	0.112		
-219	1.310				
-220	1.373				
-221	1.435				
-222	1.499				
-223	1.623				
-224	1.748				
-225	1.873				12°-15°
-226	1.998				
-227	2.123				

DASH NO.	ØM	T	W	G	A
-228	2.248				
-229	2.373	0.062	0.112	0.006	12°-15°
-230	2.498			0.000	
-325	1.498				
-326	1.623				
-327	1.748				
-328	1.873				
-329	1.998				
-330	2.123				19°-22°
-331	2.248				
-332	2.373				
-333	2.498				
-334	2.624				
-335	2.748				
-338	2.873				
-337	2.997	0.088	0.173	0.007	
-338	3.122			0.000	
-339	3.247				
-340	3.372				
-341	3.497				
-342	3.622				
-343	3.747				
-344	3.872				
-345	3.997				
-346	4.122				12°-15°
-347	4.247				
-348	4.373				
-349	4.499				
-425	4.497				
-426	4.622				
-427	4.747				
-428	4.872	0.128	0.228	0.008	
-429	4.997			0.000	
-430	5.122				
-431	5.247				

- 1 tetralon materials
- 2 back-up rings
- 3 metaplast II spring seals
- 4 tetracap & unilock seals
- 5 tetraflex piston seals
- 6 o-rings
- 7 metallic seals
- 8 tetralon bearings

# Back-Up Rings

TF1201R Single Turn, Rod

DASH NO.	ØM	T	W	G	A
-432	5.372				
-433	5.497	0.128	0.228	0.008 0.000	12°-15°
-434	5.622				

DASH NO.	ØM	T	W	G	A
-435	5.747				
-436	5.872	0.128	0.228	0.008 0.000	12°-15°
-437	5.997				

# Back-Up Rings

TF450 Single Turn, Heavy Duty

**TF450**  
(BACR12BM)

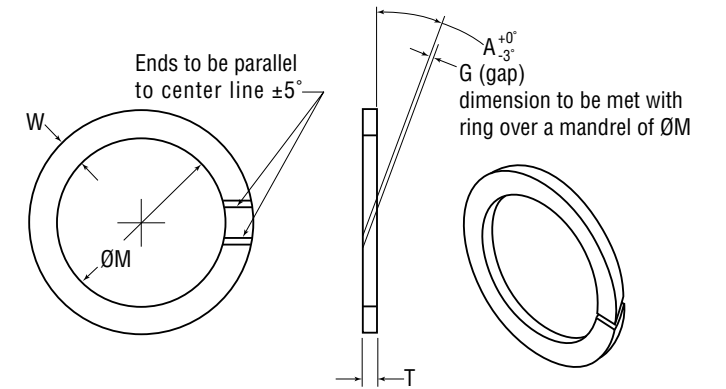

**Notes:**  
 1. Dimension A in degrees, all others in inches.  
 2. This part dimensionally equivalent to Boeing SCD BAC R12 BM. If ordered under the Boeing part number, it will be supplied to BMS 8-121, Type I, Class I, Grade B. If ordered under TF450, it will be supplied in TFE per AMS 3656 / AMS 3660.  
 3. Dash numbers correspond to those of AS-568 numbering system.  
 4. This part is designed for use in glands per MIL-P-5514C thru F.  
 5. Gap dimension to be met with retainer over a mandrel of ØM.

DASH NO.	ØM	Tol.	T	W	G	A
-001	0.028					60°
-002	0.037					45°
-003	0.045					30°
-004	0.076					
-005	0.108					
-006	0.123					
-007	0.154					
-008	0.185					
-009	0.217					
-010	0.248					
-011	0.310					
-012	0.373	±0.001	0.058	0.054	0.005	22°
-013	0.438		0.054	0.052	0.000	
-014	0.501					
-015	0.563					
-016	0.626					
-017	0.688					
-018	0.751					
-019	0.813					
-020	0.881					
-021	0.943					
-022	1.006					
-023	1.068					
-024	1.131					

DASH NO.	ØM	Tol.	T	W	G	A
-025	1.193					
-026	1.256	±0.001	0.058	0.054	0.005	22°
-027	1.318		0.054	0.052	0.000	
-028	1.381					
-110	0.373					
-111	0.435					
-112	0.498					
-113	0.560					
-114	0.623					
-115	0.685					
-116	0.748					
-117	0.815					
-118	0.878					
-119	0.940					
-120	1.003	±0.001	0.062	0.087	0.006	22°
-121	1.065		0.058	0.085	0.000	
-122	1.128					
-123	1.190					
-124	1.253					
-125	1.315					
-126	1.380					
-127	1.442					
-128	1.505					
-129	1.564					

- 1 tetralon materials
- 2 back-up rings
- 3 metaplast II spring seals
- 4 tetracap & unilock seals
- 5 tetraflex piston seals
- 6 o-rings
- 7 metallic seals
- 8 tetralon bearings

# Back-Up Rings

TF450 Single Turn, Heavy Duty

DASH NO.	ØM	Tol.	T	W	G	A
-130	1.627					
-131	1.689					
-132	1.752					
-133	1.814					
-134	1.877	±0.001	0.062	0.087	0.006	22°
-135	1.940		0.058	0.085	0.000	
-136	2.002					
-137	2.065					
-138	2.127					
-139	2.190					
-210	0.748					
-211	0.810					
-212	0.873					
-213	0.935					
-214	0.998				0.006	
-215	1.060				0.000	
-216	1.123					
-217	1.185					
-218	1.248					
-219	1.310					
-220	1.373	±0.001				
-221	1.435					
-222	1.498		0.060	0.118		22°
-223	1.625		0.064	0.120		
-224	1.750					
-225	1.875					
-226	2.000					
-227	2.125				0.007	
-228	2.250				0.000	
-229	2.375					
-230	2.500					
-231	2.625					
-232	2.750	±0.002				
-233	2.875					
-234	3.000					
-235	3.125					
-236	3.250					
-237	3.375					
-238	3.500	±0.002				
-239	3.625					
-240	3.750					
-241	3.875		0.060	0.118	0.007	22°
-242	4.000		0.064	0.120	0.000	
-243	4.125					
-244	4.250					
-245	4.375	±0.003				
-246	4.500					
-247	4.625					
-325	1.498					
-326	1.623					
-327	1.748					
-328	1.873					
-329	1.998					
-330	2.123					
-331	2.248					
-332	2.373					
-333	2.498					
-334	2.623					
-335	2.748	±0.001	0.088	0.182	0.007	17°
-336	2.873		0.092	0.184	0.000	
-337	2.997					
-338	3.122					
-339	3.247					
-340	3.372					
-341	3.497					
-342	3.622					
-343	3.747					
-344	3.872					
-345	3.997					
-346	4.122					

# Back-Up Rings

TF450 Single Turn, Heavy Duty

DASH NO.	ØM	Tol.	T	W	G	A
-347	4.247					
-348	4.372	±0.001	0.088	0.182	0.007	17°
-349	4.497		0.092	0.184	0.000	
-425	4.497					
-426	4.622					
-427	4.747	±0.001	0.118	0.235	0.008	17°
-428	4.872		0.122	0.237	0.000	
-429	4.997					
-430	5.122					
-431	5.247					
-432	5.372					
-433	5.497	±0.001	0.118	0.235	0.008	17°
-434	5.622		0.122	0.237	0.000	
-435	5.747					
-436	5.872					
-437	5.997					

- 1 tetralon materials
- 2 back-up rings
- 3 metaplast II spring seals
- 4 tetracap & unilock seals
- 5 tetraflex piston seals
- 6 o-rings
- 7 metallic seals
- 8 tetralon bearings

# Back-Up Rings

TF74C Single Turn / TF74S Solid Extended Series

## TF74C Back-Up, Single Turn

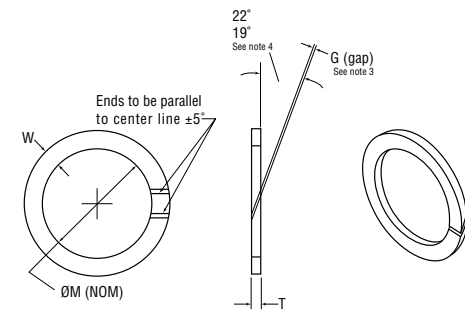

- Notes:**
- All dimensions are in inches
  - Surfaces shall be smooth and free from irregularities. Edges shall be clear and sharp.
  - Scarf cut: Placing Back-Up Ring over mandrel of Ø M ±0.001 scarf cut gap shall not exceed dimension G and no overlap of the scarf ends is permitted beyond dimension T.
  - Direction of scarf cut is optional. Exceptions to scarf cut angle:

Dash No.	Angle
-001 to -003	41° - 45°
-004	35° - 39°
-005	27° - 29°
-006	24° - 26°
-007	19° - 20°
-102 to -106	41° - 45°

## TF74S Back-Up, Solid

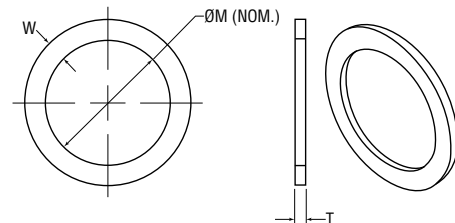

TF74S and TF74C contain dash sizes beyond those shown on TF74 and TF95

DASH NO.	ØM	T	W	G
-001	1/32		0.029/0.031	
-002	3/64	0.040 0.045	0.039/0.041	
-003	1/16		0.046/0.048	
-004	5/64			
-005	3/32			
-006	1/8			
-007	5/32			
-008	3/16			
-009	7/32			
-010	1/4			
-011	5/16			
-012	3/8			0.005 0.000
-013	7/16	0.052 0.045	0.054 0.052	
-014	1/2			
-015	9/16			
-016	5/8			
-017	11/16			
-018	3/4			
-019	13/16			
-020	7/8			
-021	15/16			
-022	1			
-023	1 1/16			
-024	1 1/8			

DASH NO.	ØM	T	W	G
-025	1 3/16			
-026	1 1/4			0.005 0.000
-027	1 5/16			
-028	1 3/8			
-029	1 1/2			
-030	1 5/8			
-031	1 3/4			
-032	1 7/8			
-033	2			
-034	2 1/8			
-035	2 1/4			
-036	2 3/8	0.052	0.054	
-037	2 1/2	0.045	0.052	0.006 0.000
-038	2 5/8			
-039	2 3/4			
-040	2 7/8			
-041	3			
-042	3 1/4			
-043	3 1/2			
-044	3 3/4			
-045	4			
-046	4 1/4			
-047	4 1/2			0.007 0.000
-048	4 3/4			

DASH NO.	ØM	T	W	G
-049	5	0.052	0.054	0.007
-050	5 1/4	0.045	0.052	0.000
-102	1/16			
-103	3/32			
-104	1/8			
-105	3/32	0.052	0.087	0.005
-106	3/16	0.045	0.085	0.000
-107	7/32			
-108	1/4			
-109	5/16			
-110	3/8			
-111	7/16			
-112	1/2			
-113	9/16			
-114	5/8			
-115	11/16			
-116	3/4	0.052	0.087	0.006
-117	13/16	0.045	0.085	0.000
-118	7/8			
-119	15/16			
-120	1			
-121	1 1/16			
-122	1 1/8			
-123	1 3/16			

TF74C Single Turn / TF74S Solid Extended Series

DASH NO.	ØM	T	W	G
-124	1 1/4			
-125	1 5/16			
-126	1 3/8			
-127	1 7/16			
-128	1 1/2			
-129	1 7/16			
-130	1 5/8			
-131	1 11/16			0.006 0.000
-132	1 3/4			
-133	1 13/16			
-134	1 7/8			
-135	1 15/16			
-136	2			
-137	2 1/16			
-138	2 1/8			
-139	2 3/16			
-140	2 1/4			
-141	2 5/16	0.052 0.045	0.087 0.085	
-142	2 3/8			
-143	2 7/16			
-144	2 1/2			0.007 0.000
-145	2 9/16			
-146	2 5/8			
-147	2 11/16			
-148	2 3/4			
-149	2 13/16			
-150	2 7/8			0.008 0.000
-151	3			
-152	3 1/4			
-153	3 1/2			
-154	3 3/4			
-155	4			
-156	4 1/4			
-157	4 1/2			
-158	4 3/4			

DASH NO.	ØM	T	W	G
-159	5			
-160	5 1/4			
-161	5 1/2			
-162	5 3/4			
-163	6			
-164	6 1/4			
-165	6 1/2			
-166	6 3/4			
-167	7			
-168	7 1/4	0.052 0.045	0.087 0.085	0.008 0.000
-169	7 1/2			
-170	7 3/4			
-171	8			
-172	8 1/4			
-173	8 1/2			
-174	8 3/4			
-175	9			
-176	9 1/4			
-177	9 1/2			
-178	9 3/4			
-201	3/16			
-202	1/4			
-203	5/16			
-204	3/8			
-205	7/16			
-206	1/2			
-207	9/16	0.052 0.045	0.120 0.118	0.006 0.000
-208	5/8			
-209	11/16			
-210	3/4			
-211	13/16			
-212	7/8			
-213	15/16			
-214	1			

DASH NO.	ØM	T	W	G
-215	1 1/16			
-216	1 1/8			
-217	1 3/16			
-218	1 1/4			
-219	1 5/16			0.006 0.000
-220	1 3/8			
-221	1 7/16			
-222	1 1/2			
-223	1 5/8			
-224	1 3/4			
-225	1 7/8			
-226	2			
-227	2 1/8			
-228	2 1/4			
-229	2 3/8			
-230	2 1/2			
-231	2 5/8	0.052 0.045	0.120 0.118	
-232	2 3/4			
-233	2 7/8			
-234	3			
-235	3 1/8			0.007 0.000
-236	3 1/4			
-237	3 3/8			
-238	3 1/2			
-239	3 5/8			
-240	3 3/4			
-241	3 7/8			
-242	4			
-243	4 1/8			
-244	4 1/4			
-245	4 3/8			
-246	4 1/2			
-247	4 5/8			
-248	4 3/4			
-249	4 7/8			0.008 0.000

- 1 tetralon materials
- 2 back-up rings
- 3 metaplast II spring seals
- 4 tetracap & unilock seals
- 5 tetraflex piston seals
- 6 o-rings
- 7 metallic seals
- 8 tetralon bearings

# Back-Up Rings

TF74C Single Turn / TF74S Solid, Extended Series

DASH NO.	ØM	T	W	G	DASH NO.	ØM	T	W	G	DASH NO.	ØM	T	W	G
-250	5				-309	7/16				-344	3 3/8			
-251	5 1/8				-310	1/2				-345	4			
-252	5 1/4				-311	9/16				-346	4 1/8			0.007
-253	5 3/8				-312	5/8				-347	4 1/4			0.000
-254	5 1/2				-313	11/16				-348	4 3/8			
-255	5 5/8				-314	3/4				-349	4 1/2			
-256	5 3/4			0.008	-315	13/16				<b>-350</b>	4 5/8			
-257	5 7/8			0.000	-316	7/8			0.006	-351	4 3/4			
-258	6				-317	15/16			0.000	-352	4 7/8			
-259	6 1/4				-318	1				-353	5			
-260	6 1/2				-319	1 1/16				-354	5 1/8			
-261	6 3/4				-320	1 1/8				-355	5 1/4			
-262	7				-321	1 3/16				-356	5 3/8			
-263	7 1/4				-322	1 1/4				-357	5 1/2			
-264	7 1/2				-323	1 5/16				-358	5 5/8			0.008
-265	7 3/4				-324	1 3/8				-359	5 3/4			0.000
-266	8				<b>-325</b>	1 1/2				-360	5 5/8			
-267	8 1/4	0.052	0.120		-326	1 5/8	0.075	0.184		-361	6	0.075	0.184	
-268	8 1/2	0.045	0.118		-327	1 3/4	0.065	0.182		-362	6 1/4	0.065	0.182	
-269	8 3/4				-328	1 7/8				-363	6 1/2			
-270	9				-329	2				-364	6 3/4			
-271	9 1/4				-330	2 1/8				-365	7			
-272	9 1/2				-331	2 1/4				-366	7 1/4			
-273	9 3/4				-332	2 3/8				-367	7 1/2			
-274	10			0.009	-333	2 1/2				-368	7 3/4			
-275	10 1/2			0.000	-334	2 5/8				-369	8			
-276	11				-335	2 3/4			0.007	-370	8 1/4			
-277	11 1/2				-336	2 7/8			0.000	-371	8 1/2			
-278	12				-337	3				-372	8 3/4			
-279	13				-338	3 1/8				-373	9			0.009
-280	14				-339	3 1/4				-374	9 1/4			0.000
-281	15				-340	3 3/8				<b>-375</b>	9 1/2			
-282	16				-341	3 1/2				-376	9 3/4			
-283	17				-342	3 5/8				-377	10			
-284	18				-343	3 3/4				-378	10 1/2			

Dash Nos. 325 thru 349 correspond to TF74 and TF95 Dash Sizes

# Back-Up Rings

TF74C Single Turn / TF74S Solid, Extended Series

DASH NO.	ØM	T	W	G	DASH NO.	ØM	T	W	G	DASH NO.	ØM	T	W	G
-379	11				-431	5 1/4				-454	12 1/2			
-380	11 1/2				-432	5 3/8				-455	13			
-381	12				-433	5 1/2				-456	13 1/2			
-382	13				-434	5 5/8				-457	14			
-383	14			0.009	-435	5 3/4			0.000	-458	14 1/2			
-384	15				-436	5 7/8				-459	15			0.009
-385	16				-437	6				-460	15 1/2			0.000
-386	17				-438	6 1/4				-461	16			
-387	18	0.075	0.184		-439	6 1/2				-462	16 1/2			
-388	19	0.065	0.182		-440	6 3/4				-463	17			
-389	20				-441	7				-464	17 1/2	0.110	0.237	
-390	21				-442	7 1/4	0.110	0.237		-465	18	0.100	0.236	
-391	22				-443	7 1/2	0.100	0.236		-466	18 1/2			
-392	23			0.010	-444	7 3/4			0.000	-467	19			
-393	24				-445	8				-468	19 1/2			
-394	25				-446	8 1/2				-469	20			
-395	26				-447	9			0.009	-470	21			0.010
<b>-425</b>	4 1/2				-448	9 1/2			0.000	-471	22			0.000
-426	4 5/8				-449	10				-472	23			
-427	4 3/4	0.110	0.237	0.008	-450	10 1/2			0.000	-473	24			
-428	4 7/8	0.100	0.236	0.000	-451	11				-474	25			
-429	5				-452	11 1/2				<b>-475</b>	26			
-430	5 1/8				-453	12								

Dash Nos. 425 thru 460 correspond to TF74 and TF95 Dash Sizes

- 1 tetralon materials
- 2 back-up rings
- 3 metaplast II spring seals
- 4 tetracap & unilock seals
- 5 tetraflex piston seals
- 6 o-rings
- 7 metallic seals
- 8 tetralon bearings

# Back-Up Rings

TF95 Solid

## TF95 (MS27595)

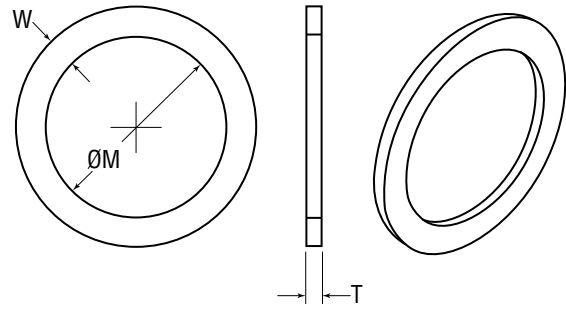

- Notes:**
1. Surfaces must be smooth and free from irregularities. Edges must be clean and sharp.
  2. Dimensions in inches.
  3. For use in packing grooves conforming to specifications MIL-G-5514, not for use in O.D. (Piston) applications using MIL-P-5514 A & B glands.
  4. For single turn ring (cut) see MS 28774 (TF74).
  5. For extended sizes solid backup rings see TF74S.
  6. Material: Tetrafluoroethylene, MIL-R-8791.

DASH NO.	ØM	Tol.	T	W	DASH NO.	ØM	Tol.	T	W	DASH NO.	ØM	Tol.	T	W
-004	0.080				-112	0.499				-139	2.192			
-005	0.111				-113	0.562				-140	2.254			
-006	0.125				-114	0.624				-141	2.317			
-007	0.156				-115	0.687				-142	2.379			
-008	0.187				-116	0.749	0.001			-143	2.442			
-009	0.219				-117	0.815				-144	2.504	0.002		0.089
-010	0.250				-118	0.877				-145	2.567			0.087
-011	0.312				-119	0.940				-146	2.629			
-012	0.375	0.001			-120	1.002				-147	2.692			
-013	0.440				-121	1.065				-148	2.754			
-014	0.503				-122	1.127				-149	2.817			
-015	0.565				-123	1.190				-210	0.753			
-016	0.628			0.056	-124	1.252				-211	0.815	0.001		
-017	0.690		0.052	0.054	-125	1.315		0.052	0.089	-212	0.878		0.052	0.048
-018	0.753		0.048		-126	1.377		0.048	0.087	-213	0.940			
-019	0.815				-127	1.440				-214	1.003			
-020	0.881				-128	1.502				-215	1.065			
-021	0.943				-129	1.565	0.002			-216	1.128			
-022	1.006				-130	1.629				-217	1.190			0.120
-023	1.068				-131	1.691				-218	1.253			0.118
-024	1.131				-132	1.754				-219	1.315	0.002		
-025	1.193	0.002			-133	1.816				-220	1.378			
-026	1.256				-134	1.879				-221	1.440			
-027	1.318				-135	1.942				-222	1.503			
-028	1.381				-136	2.004				-223	1.629			
-110	0.374			0.089	-137	2.067				-224	1.754			
-111	0.437	0.001		0.087	-138	2.129				-225	1.880			

# Back-Up Rings

TF95 Solid

DASH NO.	ØM	Tol.	T	W	DASH NO.	ØM	Tol.	T	W	DASH NO.	ØM	Tol.	T	W
-226	2.005				-331	2.248				-434	5.627			
-227	2.130				-332	2.373				-435	5.752			
-228	2.255				-333	2.498				-436	5.877			
-229	2.380				-334	2.623				-437	6.002			
-230	2.505				-335	2.748				-438	6.252			
-231	2.630				-336	2.873				-439	6.502			
-232	2.755				-337	2.998				-440	6.752	0.002		
-233	2.880				-338	3.230				-441	7.002			
-234	3.005				-339	3.248				-442	7.252			
-235	3.130				-340	3.373		0.075	0.186	-443	7.502			
-236	3.255		0.052	0.120	-341	3.498		0.071	0.184	-444	7.752			
-237	3.380		0.048	0.118	-342	3.623				-445	8.002			
-238	3.505				-343	3.748				-446	8.502			
-239	3.630	0.002			-344	3.873	0.002			-447	9.002		0.110	0.237
-240	3.755				-345	3.998				-448	9.502	0.003	0.106	0.235
-241	3.880				-346	4.123				-449	10.002			
-242	4.005				-347	4.248				-450	10.502			
-243	4.130				-348	4.373				-451	11.002			
-244	4.255				-349	4.498				-452	11.502			
-245	4.380				-425	4.502				-453	12.002	0.004		
-246	4.505				-426	4.627				-454	12.502			
-247	4.630				-427	4.752				-455	13.002			
-325	1.497				-428	4.877				-456	13.502			
-326	1.622				-429	5.002		0.110	0.237	-457	14.002			
-327	1.748				-430	5.127		0.106	0.235	-458	14.502	0.005		
-328	1.873		0.075	0.186	-431	5.252				-459	15.002			
-329	1.998		0.071	0.184	-432	5.377				-460	15.502			
-330	2.123				-433	5.502								

- 1 tetralon materials
- 2 back-up rings
- 3 metaplast II spring seals
- 4 tetracap & unilock seals
- 5 tetraflex piston seals
- 6 o-rings
- 7 metallic seals
- 8 tetralon bearings

# Back-Up Rings

TF456 Solid, Heavy Duty

**TF456**  
(BACR12BP)

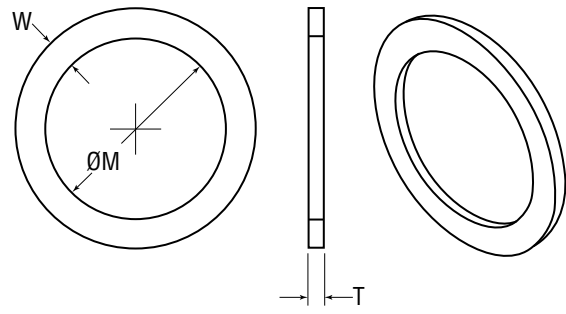

All dimensions in inches

- Notes:**  
 1. All dimensions in inches.  
 2. This part dimensionally equivalent to Boeing SCD BAC R12 BP. If ordered under the Boeing part number, it will be supplied to BMS 8-121, Type I, Class I, Grade B. If ordered under TF-456, it will be supplied in TFE per AMS 3660/3656.  
 3. Dash numbers correspond to those of AS-568 numbering system.  
 4. This part is designed for use in glands per MIL-P-5514C thru F.

DASH NO.	ØM	Tol.	T	W	DASH NO.	ØM	Tol.	T	W	DASH NO.	ØM	Tol.	T	W
-012	0.375	±0.001	0.058 0.054	0.054 0.052	-120	1.005	±0.002	0.062 0.058	0.087 0.085	-210	0.750	±0.002	0.064 0.060	0.120 0.118
-013	0.440				-121	1.067				-211	0.812			
-014	0.503	-122			1.130	-212				0.875				
-015	0.565	-123			1.192	-213				0.937				
-016	0.628	-124			1.255	-214				1.000				
-017	0.690	-125			1.317	-215				1.062				
-018	0.753	-126			1.382	-216				1.125				
-019	0.815	-127			1.444	-217				1.187				
-020	0.883	-128			1.507	-218				1.250				
-021	0.945	±0.002			-129	1.566				-219	1.312			
-022	1.008	-130	1.629	-220	1.375									
-023	1.070	-131	1.691	-221	1.437									
-024	1.133	-132	1.754	-222	1.500									
-025	1.195	-133	1.816	-223	1.627									
-026	1.258	-134	1.879	-224	1.752									
-027	1.320	-135	1.942	-225	1.877									
-028	1.383	-136	2.004	-226	2.002									
-110	0.375	±0.002	0.062 0.058	0.087 0.085	-137	2.067	±0.003	0.064 0.060	0.120 0.118	-227	2.127			
-111	0.437				-138	2.129				-228	2.252			
-112	0.500				-139	2.192				-229	2.377			
-113	0.562				-140	2.254				-230	2.502			
-114	0.625				-141	2.317				-231	2.627			
-115	0.687				-142	2.379				-232	2.752			
-116	0.750				-143	2.442				-233	2.877			
-117	0.817				-144	2.504								
-118	0.880				-145	2.567								
-119	0.942				-146	2.629								

# Back-Up Rings

TF456 Solid, Heavy Duty

DASH NO.	ØM	Tol.	T	W	DASH NO.	ØM	Tol.	T	W	DASH NO.	ØM	Tol.	T	W
-234	3.002	±0.004	0.064 0.060	0.120 0.118	-268	8.502	±0.002	0.092 0.088	0.184 0.182	-427	4.749	±0.005	0.122 0.118	0.237 0.235
-235	3.127				-269	8.752				-428	4.874			
-236	3.252				-270	9.002				-429	4.999			
-237	3.377				-271	9.252				-430	5.124			
-238	3.502				-272	9.502				-431	5.249			
-239	3.627				-273	9.752				-432	5.374			
-240	3.752				-274	10.002				-433	5.499			
-241	3.877				-325	1.500				-434	5.624			
-242	4.002				-326	1.625				-435	5.749			
-243	4.127				-327	1.750				-436	5.874			
-244	4.252	±0.003	0.064 0.060	0.120 0.118	-437	5.999	±0.006	0.122 0.118	0.237 0.235					
-245	4.377				-328	1.875				-438	6.249			
-246	4.502				-329	2.000				-439	6.499			
-247	4.627				-330	2.125				-440	6.749			
-248	4.752				-331	2.250				-441	6.999			
-249	4.877				-332	2.375				-442	7.249			
-250	5.002				-333	2.500				-443	7.499			
-251	5.127				-334	2.625				-444	7.749			
-252	5.252				-335	2.750				-445	7.999			
-253	5.377				-336	2.875				-446	8.499			
-254	5.502	±0.004	0.064 0.060	0.120 0.118	-337	2.999	±0.008	0.122 0.118	0.237 0.235					
-255	5.627				-338	3.124				-447	8.999			
-256	5.752				-339	3.249				-448	9.499			
-257	5.877				-340	3.374				-449	9.999			
-258	6.002				-341	3.499				-450	10.499			
-259	6.252				-342	3.624				-451	10.999			
-260	6.502				-343	3.749				-452	11.499			
-261	6.752				-344	3.874				-453	11.999			
-262	7.002				-345	3.999				-454	12.499			
-263	7.252				±0.005	0.064 0.060				0.120 0.118	-346	4.124	±0.010	0.122 0.118
-264	7.502	-347	4.249	-455			12.999							
-265	7.752	-348	4.374	-456			13.499							
-266	8.002	-349	4.499	-457			13.999							
-267	8.252	-425	4.499	-458			14.499							
		-426	4.624	-459			14.999							
				-460			15.499							

- 1 tetralon materials
- 2 back-up rings
- 3 metaplast II spring seals
- 4 tetracap & unilock seals
- 5 tetraflex piston seals
- 6 o-rings
- 7 metallic seals
- 8 tetralon bearings

# Back-Up Rings

TF82 Spiral

## TF82 (MS28782)

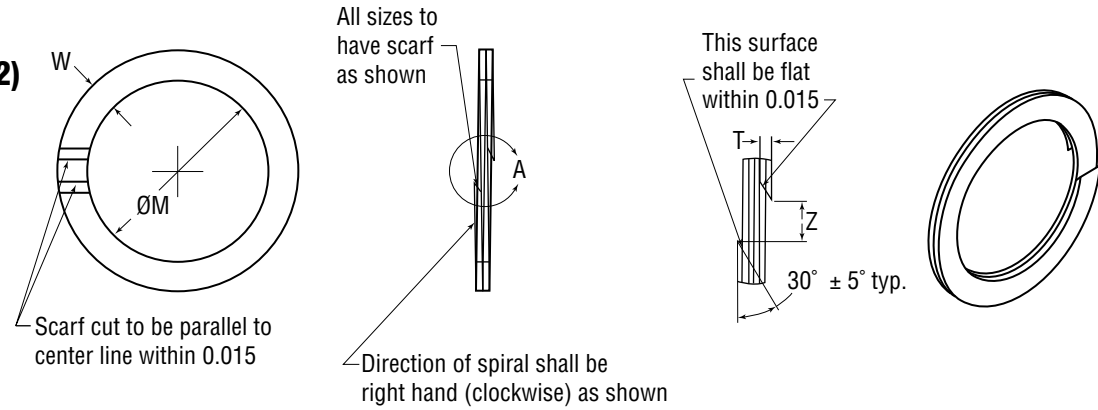

- Notes:**  
 1. Material: PTFE AS8791.  
 2. Surface must be smooth and free from irregularities.  
 3. Dimensions in inches.

4. Z gap dimension to be met with back-up ring over a mandrel of M Dia. + 0.00 - 0.002.  
 5. Dash numbers correspond to the dash numbers of AN6227 packing.  
 6. Coils to be flat and to remain closed within 0.250 inch total in the free condition.  
 7. See TF171 for additional sizes.

DASH NO.	ØM	T		W		Z	
		Max.	Min.	Max.	Min.	Max.	Min.
-1	0.125						
-2	0.156						
-3	0.188						
-4	0.219			0.056	0.054	0.062	
-5	0.250						
-6	0.312						
-7	0.375						0.032
-8	0.375						
-9	0.438						
-10	0.500						
-11	0.562	0.029	0.025	0.089	0.087	0.078	
-12	0.625						
-13	0.688						
-14	0.750						
-15	0.750						
-16	0.812						
-17	0.875						
-18	0.938						
-19	1.000			0.122	0.120	0.093	0.047
-20	1.062						
-21	1.125						
-22	1.188						

DASH NO.	ØM	T		W		Z	
		Max.	Min.	Max.	Min.	Max.	Min.
-23	1.250						
-24	1.312						
-25	1.375	0.029	0.025	0.122	0.120	0.093	0.047
-26	1.438						
-27	1.500						
-28	1.500						
-29	1.625						
-30	1.750						
-31	1.875						
-32	2.000						
-33	2.125						
-34	2.250					0.188	0.062
-35	2.375						
-36	2.500	0.036	0.031	0.186	0.184		
-37	2.625						
-38	2.750						
-39	2.875						
-40	3.000						
-41	3.125						
-42	3.250					0.250	0.093
-43	3.375						
-44	3.500						

# Back-Up Rings

TF82 Spiral

DASH NO.	ØM	T		W		Z	
		Max.	Min.	Max.	Min.	Max.	Min.
-45	3.625						
-46	3.750	0.036	0.031	0.186	0.184	0.250	0.093
-47	3.875						
-48	4.000						
-49	4.125						
-50	4.250						
-51	4.375						
-52	4.500						
-53	4.625						
-54	4.750						
-55	4.875						
-56	5.000						
-57	5.125						
-58	5.250	0.052	0.046	0.239	0.237	0.312	0.188
-59	5.375						
-60	5.500						
-61	5.625						
-62	5.750						
-63	5.875						
-64	6.000						
-65	6.250						
-66	6.500						

DASH NO.	ØM	T		W		Z	
		Max.	Min.	Max.	Min.	Max.	Min.
-67	6.750						
-68	7.000						
-69	7.250						
-70	7.500						
-71	7.750						
-72	8.000						
-73	8.500						
-74	9.000						
-75	9.500						
-76	10.000						
-77	10.500						
-78	11.000	0.052	0.046	0.239	0.237	0.312	0.188
-79	11.500						
-80	12.000						
-81	12.500						
-82	13.000						
-83	13.500						
-84	14.000						
-85	14.500						
-86	15.000						
-87	15.500						
-88	4.500						





# Back-Up Rings

TF83 Back-Up Spiral / Single Turn

## TF83 (MS28783)

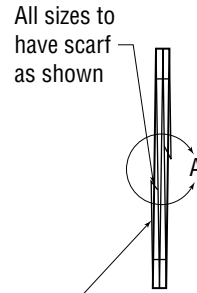

Direction of spiral shall be right hand (clockwise) as shown

T 0.029  
0.025  
Z 0.250  
0.093

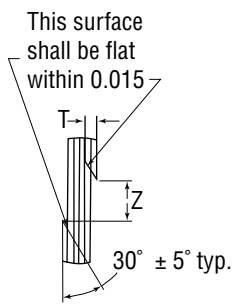

This surface shall be flat within 0.015  
30° ± 5° typ.

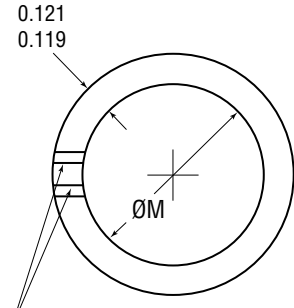

0.121  
0.119  
Scarf cut to be parallel to center line within 0.015

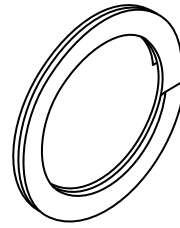

Notes:  
1. Material: TFE AS8791.  
2. Surface must be smooth and free from irregularities.  
3. Dimensions in inches.

4. Z gap dimension to be met with back-up ring over a mandrel of M Dia. + 0.00 - 0.002.  
5. Dash numbers correspond to the dash numbers of AN6230 packing.  
6. Coils to be flat and to remain closed within 0.250 inch total in the free condition.  
7. See TF171 for additional sizes.

DASH NO.	ØM	O-Ring Size
-1	1.625	-223
-2	1.750	-224
-3	1.875	-225
-4	2.000	-226
-5	2.125	-227
-6	2.250	-228
-7	2.375	-229
-8	2.500	-230
-9	2.625	-231
-10	2.750	-232
-11	2.875	-233
-12	3.000	-234
-13	3.125	-235

DASH NO.	ØM	O-Ring Size
-14	3.250	-236
-15	3.375	-237
-16	3.500	-238
-17	3.625	-239
-18	3.750	-240
-19	3.875	-241
-20	4.000	-242
-21	4.125	-243
-22	4.250	-244
-23	4.375	-245
-24	4.500	-246
-25	4.625	-247

# Back-Up Rings

TF58 Boss Connection, Single Turn / TF73 Straight Thread, Single Turn

## TF58 Boss Connection Single Turn (MS9058)

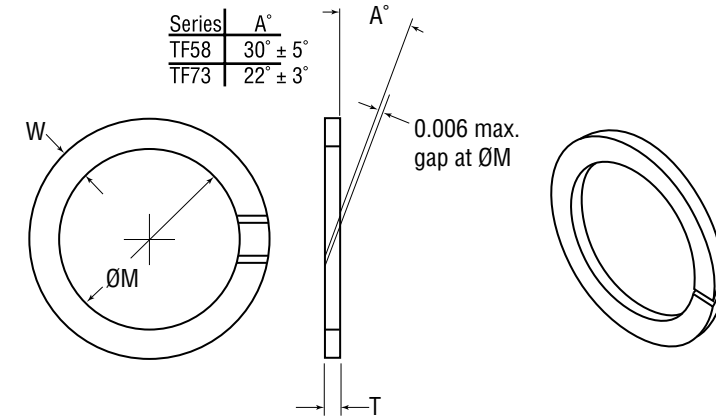

Series	A°
TF58	30° ± 5°
TF73	22° ± 3°

0.006 max. gap at ØM

Notes for TF58:  
1. Material: Polytetrafluoroethylene AMS 3656 / AMS 3660.  
2. Edges to be cut clean and square within 5°.  
3. Dimensions in inches.  
4. Dash numbers of these rings correspond to the dash numbers of standard AN-6290 O-Rings.

Notes for TF73:  
1. Material: PTFE AS8791.  
2. Surfaces must be smooth and free from irregularities. Edges must be clean and sharp.  
3. Dimensions in inches.  
4. Dash numbers of these rings correspond to the equivalent dash numbers of the MS28778 preformed packings and the AN6289 nut.  
5. Ends to be parallel within ±5°.

DASH NO.	Nom. Tube O.D.	ØM	W ±0.002	T ±0.004
-02	0.125	0.246	0.122	0.056
-03	0.188	0.309	0.112	0.056
-04	0.250	0.360	0.177	0.061
-05	0.312	0.423	0.177	0.061
-06	0.375	0.478	0.121	0.061
-07	0.438	0.549	0.121	0.061
-08	0.500	0.656	0.125	0.061
-09	0.562	0.718	0.125	0.061
-10	0.625	0.769	0.131	0.073
-11	0.688	0.878	0.159	0.073
-12	0.750	0.941	0.169	0.073
-14	0.875	1.066	0.169	0.073
-16	1.000	1.191	0.169	0.073
-18	1.125	1.378	0.169	0.073
-20	1.250	1.503	0.169	0.073
-24	1.500	1.752	0.169	0.073
-28	1.750	2.127	0.169	0.073
-32	2.000	2.377	0.169	0.073

DASH NO.	Nom. Tube O.D.	M	W ±0.001	T ±0.001
-02	1/8	0.246	0.122	0.056
-03	3/16	0.309	0.112	0.056
-04	1/4	0.360	0.117	0.061
-05	5/16	0.423	0.117	0.061
-06	3/8	0.478	0.121	0.061
-08	1/2	0.656	0.125	0.061
-10	5/8	0.769	0.131	0.073
-12	3/4	0.941	0.169	0.073
-16	1	1.191	0.169	0.073
-20	1 1/4	1.503	0.169	0.073
-24	1 1/2	1.752	0.169	0.073
-28	1 3/4	2.127	0.169	0.073
-32	2	2.377	0.169	0.073

- 1 tetralon materials
- 2 back-up rings
- 3 metaplast II spring seals
- 4 tetracap & unilock seals
- 5 tetraflex piston seals
- 6 o-rings
- 7 metallic seals
- 8 tetralon bearings

# Back-Up Rings

TF171 Spiral, Extended Series

## TF171

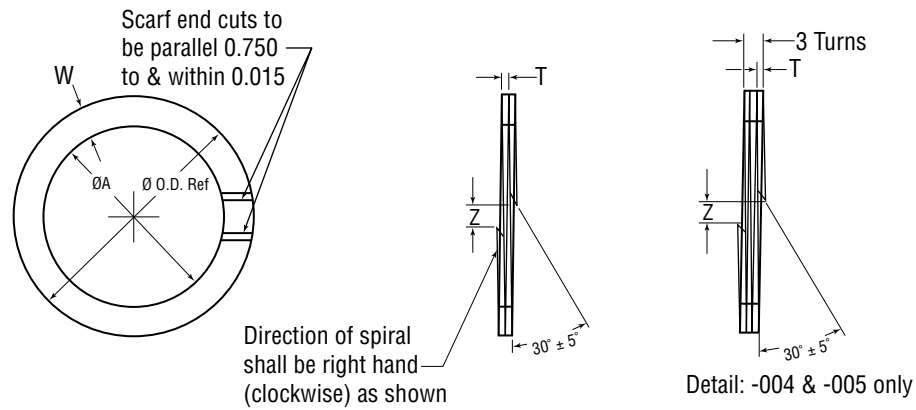

- Notes:
1. Material: AMS 3656 / AMS 3660
  2. Surface must be smooth and free from irregularities.
  3. Dimensions in inches.
  4. Z gap dimension to be met with retainer over a mandrel of ØA +0.000 -0.002
  5. Dash Numbers also correspond to Dash Numbers of MS35803 and AN6244 leather backup rings.
  6. Coils to be flat and to remain closed within 0.250 inch total in the free condition.

AS568 DASH NO.	AN6227B/AN6230B DASH NO.	Nominal		ØA	T	W	Z
		I.D.	O.D.				
-004	-----	5/64	3/16	0.078	0.019	0.054	0.062 0.032
-005	-----	7/64	7/32	0.110	0.016	0.052	
-006	AN6227B-1	1/8	1/4	0.125			
-007	AN6227B-2	5/32	9/32	0.156			
-008	AN6227B-3	3/16	5/16	0.188			
-009	AN6227B-4	7/32	11/32	0.219			
-010	AN6227B-5	1/4	3/8	0.250			
-011	AN6227B-6	5/16	7/16	0.312			
-012	AN6227B-7	3/8	1/2	0.375			
-013	-----	7/16	9/16	0.437			
-014	-----	1/2	5/8	0.500			
-015	-----	9/16	11/16	0.562			
-016	-----	5/8	3/4	0.625			
-017	-----	11/16	13/16	0.687	0.029	0.056	0.078 0.032
-018	-----	3/4	7/8	0.750	0.025	0.054	
-019	-----	13/16	15/16	0.812			
-020	-----	7/8	1	0.875			
-021	-----	15/16	1 1/16	0.937			
-022	-----	1	1 1/8	1.000			
-023	-----	1 1/16	1 3/16	1.062			
-024	-----	1 1/8	1 1/4	1.125			
-025	-----	1 3/16	1 5/16	1.187			
-026	-----	1 1/4	1 3/8	1.250			
-027	-----	1 5/16	1 7/16	1.312			
-028	-----	1 3/8	1 1/2	1.375			

# Back-Up Rings

TF171 Spiral, Extended Series

AS568 DASH NO.	AN6227B/AN6230B DASH NO.	Nominal		ØA	T	W	Z
		I.D.	O.D.				
-110	AN6227B-8	3/8	9/16	0.375			0.078 0.032
-111	AN6227B-9	7/16	5/8	0.438			
-112	AN6227B-10	1/2	11/16	0.500			
-113	AN6227B-11	9/16	3/4	0.562			
-114	AN6227B-12	5/8	13/16	0.625			
-115	AN6227B-13	11/16	7/8	0.687			
-116	AN6227B-14	3/4	15/16	0.750			
-117	-----	13/16	1	0.812			
-118	-----	7/8	1 1/16	0.875			
-119	-----	15/16	1 1/8	0.937			
-120	-----	1	1 3/16	1.000			
-121	-----	1 1/16	1 1/4	1.062			
-122	-----	1 1/8	1 5/16	1.125			
-123	-----	1 3/16	1 3/8	1.187			
-124	-----	1 1/4	1 7/16	1.250			
-125	-----	1 5/16	1 1/2	1.312			
-126	-----	1 3/8	1 9/16	1.375			
-127	-----	1 7/16	1 5/8	1.437	0.029	0.089	0.093 0.047
-128	-----	1 1/2	1 11/16	1.500	0.025	0.087	
-129	-----	1 9/16	1 3/4	1.562			
-130	-----	1 5/8	1 13/16	1.625			
-131	-----	1 11/16	1 7/8	1.687			
-132	-----	1 3/4	1 15/16	1.750			
-133	-----	1 13/16	2	1.812			
-134	-----	1 7/8	2 1/16	1.875			
-135	-----	1 15/16	2 1/8	1.937			
-136	-----	2	2 3/16	2.000			
-137	-----	2 1/16	2 1/4	2.062			
-138	-----	2 1/8	2 5/16	2.125			
-139	-----	2 3/16	2 3/8	2.187			
-140	-----	2 1/4	2 7/16	2.250			
-141	-----	2 5/16	2 1/2	2.312			
-142	-----	2 3/8	2 9/16	2.375			
-143	-----	2 7/16	2 5/8	2.437			
-144	-----	2 1/2	2 11/16	2.500			

- 1 tetralon materials
- 2 back-up rings
- 3 metaplast II spring seals
- 4 tetracap & unilock seals
- 5 tetraflex piston seals
- 6 o-rings
- 7 metallic seals
- 8 tetralon bearings

# Back-Up Rings

TF171 Spiral, Extended Series

AS568 DASH NO.	AN6227B/AN6230B DASH NO.	Nominal		ØA	T	W	Z
		I.D.	O.D.				
-145	-----	2 9/16	2 3/4	2.562			
-146	-----	2 5/8	2 13/16	2.625			
-147	-----	2 11/16	2 7/8	2.687		0.089	0.182
-148	-----	2 3/4	2 15/16	2.750		0.087	0.062
-149	-----	2 13/16	3	2.812			
-210	AN6227B-15	3/4	1 1/16	0.750			
-211	AN6227B-16	13/16	1 1/8	0.812			
-212	AN6227B-17	7/8	1 3/16	0.875			
-213	AN6227B-18	15/16	1 3/8	0.938			
-214	AN6227B-19	1	1 1/4	1.000			
-215	AN6227B-20	1 1/16	1 5/16	1.062			
-216	AN6227B-21	1 1/8	1 3/8	1.125		0.122	0.093
-217	AN6227B-22	1 3/16	1 7/16	1.188		0.120	0.047
-218	AN6227B-23	1 1/4	1 1/2	1.250			
-219	AN6227B-24	1 5/16	1 9/16	1.312			
-220	AN6227B-25	1 3/8	1 5/8	1.375			
-221	AN6227B-26	1 7/16	1 5/8	1.438			
-222	AN6227B-27	1 1/2	1 3/4	1.500	0.029		
-223	AN6230B-1	1 5/8	1 7/8	1.625	0.025		
-224	AN6230B-2	1 3/4	2	1.750			
-225	AN6230B-3	1 7/8	2 1/8	1.875			
-226	AN6230B-4	2	2 1/4	2.000			
-227	AN6230B-5	2 1/8	2 3/8	2.125			
-228	AN6230B-6	2 1/4	2 1/2	2.250			
-229	AN6230B-7	2 3/8	2 5/8	2.375			
-230	AN6230B-8	2 1/2	2 3/4	2.500			
-231	AN6230B-9	2 5/8	2 7/8	2.625		0.121	0.250
-232	AN6230B-10	2 3/4	3	2.752		0.119	0.093
-233	AN6230B-11	2 7/8	3 1/8	2.875			
-234	AN6230B-12	3	3 1/4	3.000			
-235	AN6230B-13	3 1/8	3 3/8	3.125			
-236	AN6230B-14	3 1/4	3 1/2	3.250			
-237	AN6230B-15	3 3/8	3 5/8	3.375			
-238	AN6230B-16	3 1/2	3 3/4	3.500			
-239	AN6230B-17	3 5/8	3 7/8	3.625			

# Back-Up Rings

TF171 Spiral, Extended Series

AS568 DASH NO.	AN6227B/AN6230B DASH NO.	Nominal		ØA	T	W	Z
		I.D.	O.D.				
-240	AN6230B-18	3 3/4	4	3.750			
-241	AN6230B-19	3 7/8	4 1/8	3.875			
-242	AN6230B-20	4	4 1/4	4.000			
-243	AN6230B-21	4 1/8	4 3/8	4.125			
-244	AN6230B-22	4 1/4	4 1/2	4.250			
-245	AN6230B-23	4 3/8	4 5/8	4.375			
-246	AN6230B-24	4 1/2	4 3/4	4.500			
-247	AN6230B-25	4 5/8	4 7/8	4.625			
-248	AN6230B-26	4 3/4	5	4.750			
-249	AN6230B-27	4 7/8	5 1/8	4.875			
-250	AN6230B-28	5	5 1/4	5.000			
-251	AN6230B-29	5 1/8	5 3/8	5.125			
-252	AN6230B-30	5 1/4	5 1/2	5.250			
-253	AN6230B-31	5 3/8	5 5/8	5.375			
-254	AN6230B-32	5 1/2	5 3/4	5.500			
-255	AN6230B-33	5 5/8	5 7/8	5.625			
-256	AN6230B-34	5 3/4	6	5.750			
-257	AN6230B-35	5 7/8	6 1/8	5.875	0.029	0.121	0.250
-258	AN6230B-36	6	6 1/4	6.000	0.025	0.119	0.093
-259	AN6230B-37	6 1/4	6 1/2	6.250			
-260	AN6230B-38	6 1/2	6 3/4	6.500			
-261	AN6230B-39	6 3/4	7	6.750			
-262	AN6230B-40	7	7 1/4	7.000			
-263	AN6230B-41	7 1/4	7 1/2	7.250			
-264	AN6230B-42	7 1/2	7 3/4	7.500			
-265	AN6230B-43	7 3/4	8	7.750			
-266	AN6230B-44	8	8 1/4	8.000			
-267	AN6230B-45	8 1/4	8 1/2	8.250			
-268	AN6230B-46	8 1/2	8 3/4	8.500			
-269	AN6230B-47	8 3/4	9	8.750			
-270	AN6230B-48	9	9 1/4	9.000			
-271	AN6230B-49	9 1/4	9 1/2	9.250			
-272	AN6230B-50	9 1/2	9 3/4	9.500			
-273	AN6230B-51	9 3/4	10	9.750			
-274	AN6230B-52	10	10 1/4	10.000			

- 1 tetralon materials
- 2 back-up rings
- 3 metaplast II spring seals
- 4 tetracap & unilock seals
- 5 tetraflex piston seals
- 6 o-rings
- 7 metallic seals
- 8 tetralon bearings

# Back-Up Rings

TF171 Spiral, Extended Series

AS568 DASH NO.	AN6227B/AN6230B DASH NO.	Nominal		ØA	T	W	Z
		I.D.	O.D.				
-325	AN6227B-28	1 ½	1 ⅞	1.500			
-326	AN6227B-29	1 ⅝	2	1.625			
-327	AN6227B-30	1 ¾	2 ⅛	1.750			
-328	AN6227B-31	1 ⅞	2 ¼	1.875			
-329	AN6227B-32	2	2 ⅜	2.000			
-330	AN6227B-33	2 ⅛	2 ½	2.125			0.188
-331	AN6227B-34	2 ¼	2 ⅝	2.250			0.062
-332	AN6227B-35	2 ⅜	2 ¾	2.375			
-333	AN6227B-36	2 ½	2 ⅞	2.500			
-334	AN6227B-37	2 ⅝	3	2.625			
-335	AN6227B-38	2 ¾	3 ⅛	2.750			
-336	AN6227B-39	2 ⅞	3 ¼	2.875			
-337	AN6227B-40	3	3 ⅜	3.000	0.036 0.031	0.186 0.184	
-338	AN6227B-41	3 ⅞	3 ½	3.125			
-339	AN6227B-42	3 ¼	3 ⅝	3.250			
-340	AN6227B-43	3 ⅜	3 ¾	3.375			
-341	AN6227B-44	3 ½	3 ⅞	3.500			
-342	AN6227B-45	3 ⅝	4	3.625			
-343	AN6227B-46	3 ¾	4 ⅛	3.750			0.250 0.093
-344	AN6227B-47	3 ⅞	4 ¼	3.875			
-345	AN6227B-48	4	4 ⅜	4.000			
-346	AN6227B-49	4 ⅛	4 ½	4.125			
-347	AN6227B-50	4 ¼	4 ⅝	4.250			
-348	AN6227B-51	4 ⅝	4 ¾	4.375			
-349	AN6227B-52	4 ½	4 ⅞	4.500			
-425	AN6227B-88	4 ½	5	4.500			
-426	AN6227B-53	4 ⅝	5 ⅛	4.625			
-427	AN6227B-54	4 ¾	5 ¼	4.750			
-428	AN6227B-55	4 ⅞	5 ⅜	4.875			
-429	AN6227B-56	5	5 ½	5.000	0.052 0.046	0.239 0.237	0.312 0.188
-430	AN6227B-57	5 ⅞	5 ⅝	5.125			
-431	AN6227B-58	5 ¼	5 ¾	5.250			
-432	AN6227B-59	5 ⅝	5 ⅞	5.375			
-433	AN6227B-60	5 ½	6	5.500			
-434	AN6227B-61	5 ⅝	6 ⅛	5.625			

# Back-Up Rings

TF171 Spiral, Extended Series

AS568 DASH NO.	AN6227B/AN6230B DASH NO.	Nominal		ØA	T	W	Z
		I.D.	O.D.				
-435	AN6227B-62	5 ¾	6 ¼	5.750			
-436	AN6227B-63	5 ⅞	6 ⅜	5.875			
-437	AN6227B-64	6	6 ½	6.000			
-438	AN6227B-65	6 ¼	6 ¾	6.250			
-439	AN6227B-66	6 ½	7	6.500			
-440	AN6227B-67	6 ¾	7 ¼	6.750			
-441	AN6227B-68	7	7 ½	7.000			
-442	AN6227B-69	7 ¼	7 ¾	7.250			
-443	AN6227B-70	7 ½	8	7.500			
-444	AN6227B-71	7 ¾	8 ¼	7.750			
-445	AN6227B-72	8	8 ½	8.000			
-446	AN6227B-73	8 ½	9	8.500			
-447	AN6227B-74	9	9 ½	9.000	0.052 0.046	0.239 0.237	0.312 0.188
-448	AN6227B-75	9 ½	10	9.500			
-449	AN6227B-76	10	10 ½	10.000			
-450	AN6227B-77	10 ½	11	10.500			
-451	AN6227B-78	11	11 ½	11.000			
-452	AN6227B-79	11 ½	12	11.500			
-453	AN6227B-80	12	12 ½	12.000			
-454	AN6227B-81	12 ½	13	12.500			
-455	AN6227B-82	13	13 ½	13.000			
-456	AN6227B-83	13 ½	14	13.500			
-457	AN6227B-84	14	14 ½	14.000			
-458	AN6227B-85	14 ½	15	14.500			
-459	AN6227B-86	15	15 ½	15.000			
-460	AN6227B-87	15 ½	16	15.500			

- 1 tetralon materials
- 2 back-up rings
- 3 metaplast II spring seals
- 4 tetracap & unilock seals
- 5 tetraflex piston seals
- 6 o-rings
- 7 metallic seals
- 8 tetralon bearings

**CUSTOMER DATA**

Company Name \_\_\_\_\_ Date Submitted \_\_\_\_\_  
 Address \_\_\_\_\_ Date Required \_\_\_\_\_  
 City, State, Zip, Country \_\_\_\_\_  
 Telephone \_\_\_\_\_ Fax \_\_\_\_\_  OEM  INTERNAL USE  
 Contact Person \_\_\_\_\_ Title \_\_\_\_\_  Distributor EAR # \_\_\_\_\_  
 E-Mail \_\_\_\_\_  Rebuilder Territory # \_\_\_\_\_  
 Products Mfgd/Sold/Service \_\_\_\_\_  Consultant Territory Mgr \_\_\_\_\_

**APPLICATION DATA**

1. Is this applicaton: New Design  Retrofit   
 2. Pressure Direction: In  Out   
 3. Temperature: Min. \_\_\_\_\_ Normal \_\_\_\_\_ Max. \_\_\_\_\_ °C  °F   
 4. Pressure: Min. \_\_\_\_\_ Normal \_\_\_\_\_ Max. \_\_\_\_\_ Bar  PSI  Proof \_\_\_\_\_  
 5. Media being sealed: \_\_\_\_\_  
 6. If retrofit, please describe why customer wants to consider a new seal \_\_\_\_\_  
 7. If this is a change, is there a source  spec  control drawing? Dwg # \_\_\_\_\_  
 8. Disposition of existing parts: \_\_\_\_\_

**HARDWARE DATA**

All Dimensions are in: Millimeters  Inches   
 Groove: Dia \_\_\_\_\_ - \_\_\_\_\_ + \_\_\_\_\_ Finish \_\_\_\_\_ Groove Height \_\_\_\_\_  
 Groove: Width \_\_\_\_\_ - \_\_\_\_\_ + \_\_\_\_\_ Groove Sidewall Finish \_\_\_\_\_  
 Maximum Extrusion Gap: Radial \_\_\_\_\_ Diametral \_\_\_\_\_  
 1. Is hardware plated/coated? No  Yes  Specity \_\_\_\_\_  
 2. Is seal installation tooling required? No  Yes  Not Sure   
 3. Can hardware design be changed? No  Yes  How? \_\_\_\_\_  
 4. Reference design specifications: \_\_\_\_\_  
 5. Indicate applicable hardware design requirements in sketch below while showing pressure magnitude and directions (with arrows)

Please see following page for sketches

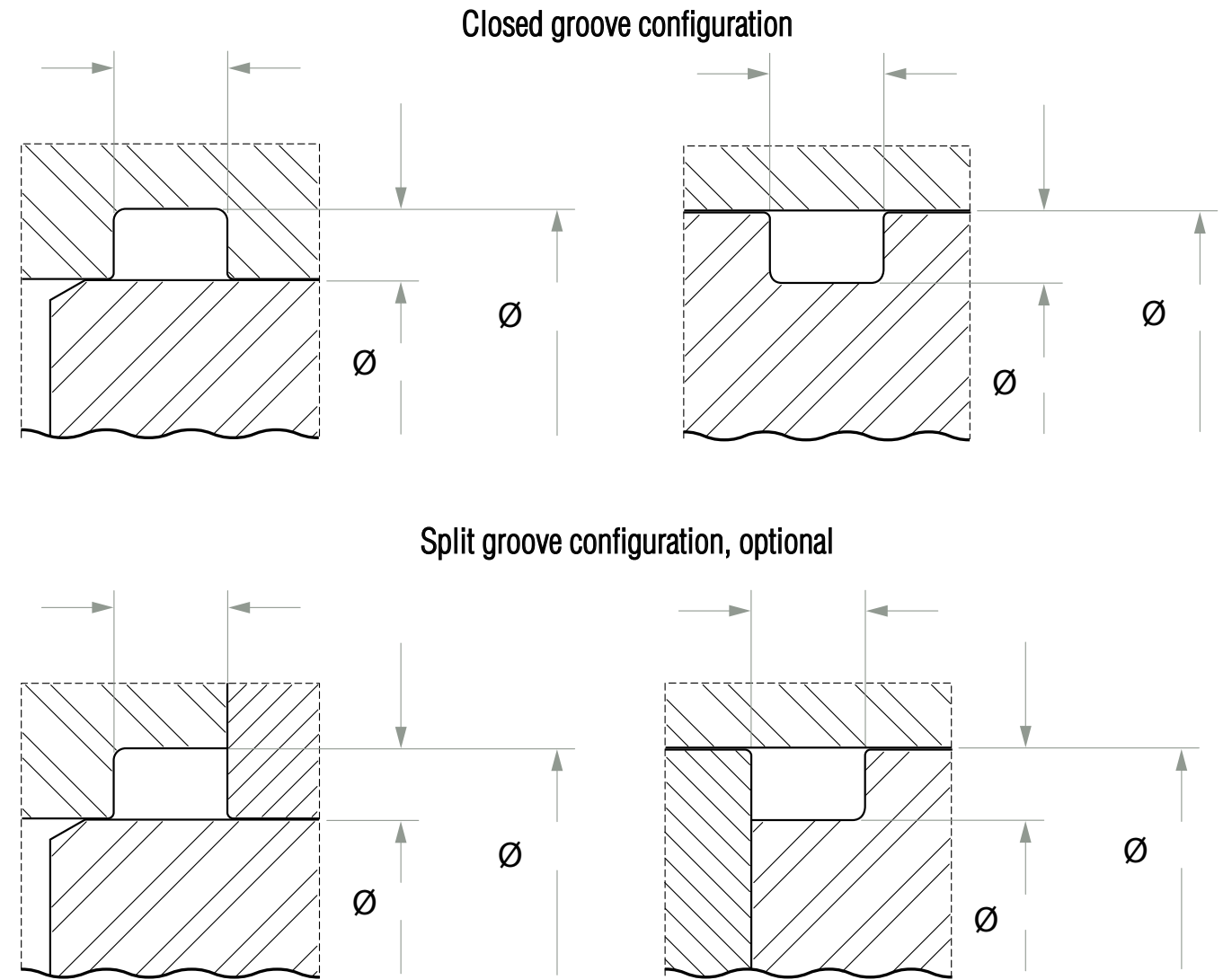

**PERFORMANCE DATA**

1. Allowable leakage (units): \_\_\_\_\_ Per \_\_\_\_\_  
 2. Desired service life: \_\_\_\_\_  
 3. Any special requirements? \_\_\_\_\_  
 4. Type of evaluation: Bench  Field  Both  Start Date \_\_\_\_\_ Duration \_\_\_\_\_  
 5. Comments: \_\_\_\_\_

- 1 tetralon materials
- 2 back-up rings
- 3 metaplast II spring seals
- 4 tetracap & unilock seals
- 5 tetratflex piston seals
- 6 o-rings
- 7 metallic seals
- 8 tetralon bearings

**Notes**

---



---



---



---



---



---



---



---



---



---



---



---



---



---



---



---



---



---



---



---



---



---

**We also offer amazing sealing solutions.**

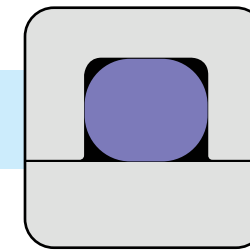

O-RING

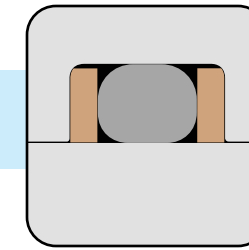

O-RING + BACK UP

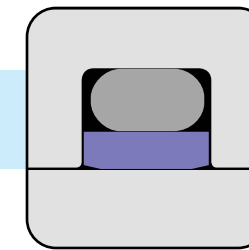

DUORING

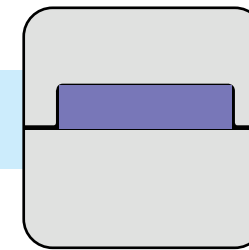

WEARRING

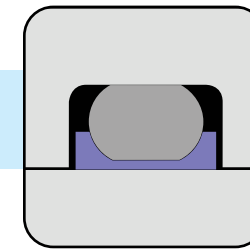

TETRACAP

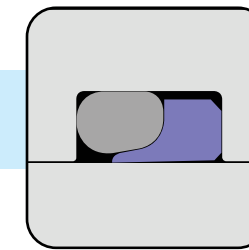

UNILOCK

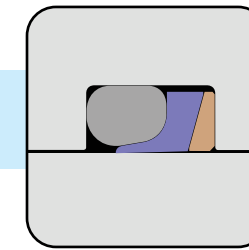

UNILOCK + BACK UP

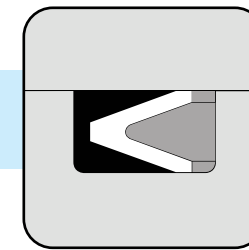

METALLIC SEALS

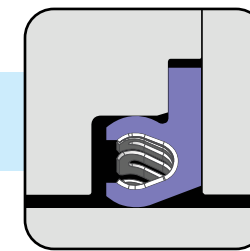

METAPLAST II  
ROTARY

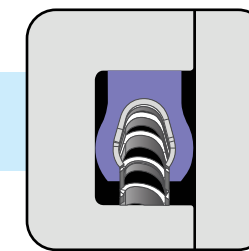

METAPLAST II  
FACE

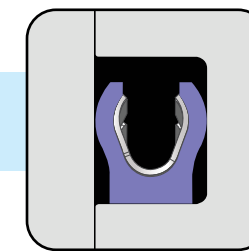

METAPLAST II  
OUTSIDE FACE

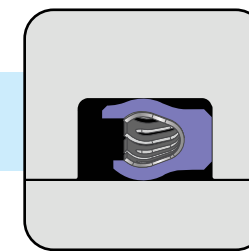

METAPLAST II  
RADIAL

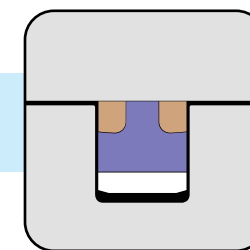

REINFORCED  
TETRAFLEX I

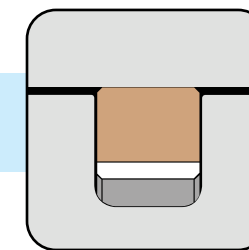

TETRAFLEX I

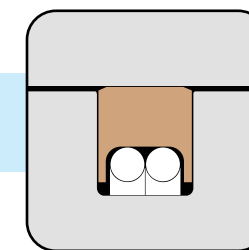

TETRAFLEX II

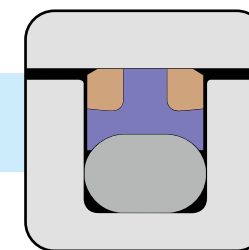

REINFORCED PISTON

1 tetralon materials

2 back-up rings

3 metaplast II spring seals

4 tetracap & unilock seals

5 tetraflex piston seals

6 o-rings

7 metallic seals

8 tetralon bearings



El Segundo, California Facility

**Serving Customers Where They Need Us Most!**

CoorsTek has over 300,000 square meters (3 million square feet) of manufacturing floor space in over 40 facilities worldwide.



CoorsTek exclusive OpX manufacturing and quality system

Note: Engineering data is representative. Property values vary somewhat with method of manufacture, size, and shape of part. Any suggested applications are not made as a representation or warranty that the material will ultimately be suitable for such applications. The customer is ultimately responsible for all design and material suitability decisions. Data contained herein is not to be construed as absolute and does not constitute a representation or warranty for which CoorsTek assumes legal responsibility. Any warranty or representation for which CoorsTek is responsible shall be subject to a separately negotiated agreement. CoorsTek, Amazing Solutions, and TetraFluor are registered trademarks of CoorsTek, Inc. OpX is a trademark of CoorsTek, Inc.